

RENTAL UNIT

OPERATING AND SERVICE MANUAL

86235A 86240A/B/C RF PLUG-IN

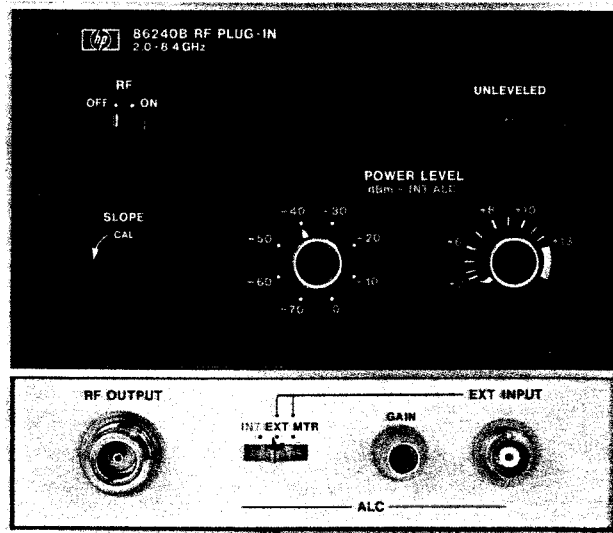

HEWLETT  PACKARD

SAFETY

This instrument has been designed and tested according to International Safety Requirements. To ensure safe operation and to keep the instrument safe, the information, cautions, and warnings in this manual must be heeded. Refer to Section I for general safety considerations applicable to this instrument.

CERTIFICATION

Hewlett-Packard Company certifies that this instrument met its published specifications at the time of shipment from the factory. Hewlett-Packard Company further certifies that its calibration measurements are traceable to the United States National Bureau of Standards, to the extent allowed by the Bureau's calibration facility, and to the calibration facilities of other International Standards Organization members.

WARRANTY AND ASSISTANCE

This Hewlett-Packard product is warranted against defects in materials and workmanship for a period of one year from the date of shipment. Hewlett-Packard will, at its option, repair or replace products which prove to be defective during the warranty period provided they are returned to Hewlett-Packard. Repairs necessitated by misuse of the product are not covered by this warranty. NO OTHER WARRANTIES ARE EXPRESSED OR IMPLIED, INCLUDING BUT NOT LIMITED TO THE IMPLIED WARRANTIES OF MERCHANTABILITY AND FITNESS FOR A PARTICULAR PURPOSE. HEWLETT-PACKARD IS NOT LIABLE FOR CONSEQUENTIAL DAMAGES.

Service contracts or customer assistance agreements are available for Hewlett-Packard products that require maintenance and repair on-site.

For any assistance contact your nearest Hewlett-Packard Sales and Service Office. Addresses are provided at the back of this manual.

OPERATING AND SERVICE MANUAL

86235A
86240A/B/C
RF PLUG-IN

Includes Options 001, 002, 004, and 008

SERIAL NUMBERS

This manual applies directly to HP Model 86235A and 86240A/B/C RF Plug-ins with serial numbers prefixed 1806A.

For additional important information about serial numbers see INSTRUMENT COVERED BY MANUAL in Section I.

©Copyright HEWLETT-PACKARD COMPANY 1978
1400 FOUNTAIN GROVE PARKWAY, SANTA ROSA, CA. 95404 U.S.A.

CONTENTS

Section	Page	Section	Page
I	GENERAL INFORMATION		
	1-1. Introduction.	3-6. Safety	3-1
	1-6. Specifications	3-9. Internal Leveling (Option 001 or Standard 86240B).	3-1
	1-8. Safety Considerations.	3-12. External Crystal Detector Leveling	3-1
	1-9. General	3-14. External Power Meter Leveling.	3-2
	1-11. Safety Symbols.	3-16. External AM.	3-2
	1-12. Operation	3-18. External FM.	3-2
	1-14. Service	3-20. Phase Lock Operation (Not Available in RF Plug-ins with MLA Compatibility).	3-2
	1-18. Instruments Covered by Manual	3-23. FM-NORM-PL Switch	3-2
	1-23. Description	3-25. Operator's Maintenance – Fuses.	3-3
	1-26. Options		
	1-27. Option 001	IV	PERFORMANCE TESTS
	1-29. Option 002		4-1
	1-31. Option 004	4-1. Introduction.	4-1
	1-33. Option 008 (Model 86235A Only)	4-4. Equipment Required	4-1
	1-35. Equipment Required but Not Supplied	4-6. Abbreviated Performance Verification.	4-1
	1-37. Equipment Available	4-8. Frequency Range and Accuracy Test.	4-1
	1-38. Model 8755B/182T Swept Amplitude Analyzer	4-9. Frequency Stability Test.	4-4
	1-40. Power Meters and Crystal Detectors	4-10. Residual FM in 10 kHz Bandwidth Test.	4-8
	1-42. Model 8410B/8411A Network Analyzer.	4-11. Power Level and Variation Test	4-10
	1-44. Model 3700-Series Microwave Link Analyzer	4-12. Power Level Attenuator Accuracy Test (Option 002)	4-15
	1-46. Accessories Supplied	4-13. Harmonic Spurious Signals Test	4-17
	1-48. Accessories Available	4-14. Nonharmonic Spurious Signals Test	4-21
	1-49. Service Accessories	4-15. Residual AM Test	4-22
	1-51. Service Aids	4-16. Equivalent Source SWR Test (Option 001 or standard 86240B).	4-24
	1-53. Recommended Test Equipment	4-17. External Frequency Modulation Test	4-28
		4-18. Amplitude Modulation Test.	4-33
II	INSTALLATION/ OPERATION VERIFICATION	4-19. FM Frequency Response Test	4-35
	2-1. Introduction.	4-20. Up Converter Simulation Test (MLA Only).	4-39
	2-3. Initial Inspection.		
	2-5. Preparation for Use	V	ADJUSTMENTS
	2-6. Power Requirements		5-1
	2-8. Interconnections	5-1. Introduction.	5-1
	2-10. Mating Connectors.	5-3. Equipment Required	5-1
	2-12. Operating Environment	5-5. Factory Selected Components	5-1
	2-16. Frequency Scale Installation	5-7. Safety Considerations.	5-1
	2-18. RF Plug-in Installation and Removal	5-13. Location of Test Points and Adjustments.	5-1
	2-21. Storage and Shipment	5-15. Yig Oscillator Bias Adjustment (86240A/B/C Only).	5-3
	2-22. Environment	5-16. YIG Driver Frequency Adjustments	5-5
	2-24. Packaging.	5-17. Frequency Reference Adjustments	5-12
	2-27. Operation Verification	5-18. Harmonic Adjustments.	5-13
III	OPERATION	5-19. ALC Adjustments	5-19
	3-1. Introduction.	5-20. FM Driver Adjustment	5-23
	3-3. Panel Features	5-21. FM Frequency Response Adjustment (86240C, 86235A Option 008 Only).	5-26
	3-5. Operating Instructions		

CONTENTS (Cont'd)

Section	Page	Section	Page
VI REPLACEABLE PARTS	6-1	8-8. YIG-Filter-Oscillator (86240B Only) . . .	8-1
6-1. Introduction	6-1	8-10. Module Exchange Program	8-1
6-3. Abbreviations	6-1	8-12. Service	8-1
6-5. Replaceable Parts List	6-1	8-13. Safety	8-1
6-7. Ordering Instructions	6-1	8-17. Troubleshooting	8-2
VII Manual Backdating Changes	7-1	8-21. Recommended Test Equipment	8-2
7-1. Introduction	7-1	8-23. Cleaning Switches	8-2
VIII Service	8-1	8-25. Power Level Control R3 Removal and Replacement	8-2
8-1. Introduction	8-1	8-27. Power Level Control Knob Replacement	8-2
8-3. Assembly Service Sheets	8-1	8-29. Unleveled Lamp Removal and Replacement	8-4
8-5. Principles of Operation	8-1		
8-6. Circuit Description	8-1		

ILLUSTRATIONS

Figure	Page	Figure	Page
1-1. RF Plug-in and Accessories Supplied	1-1	3-14. Spectrum Analyzer Display of Unstabilized CW Signal	3-20
1-2. Typical Serial Number Plate	1-7	3-15. Spectrum Analyzer Display of Phase-Locked CW Signal	3-20
1-3. Service Accessories, HP Part Number 08620-60124	1-10	3-16. Increased Dynamic Range Using HP Model 8755B Swept Amplitude Analyzer . . .	3-21
1-4. Service Aids for 86235A/86240A/B/C	1-11	4-1. CW and Manual Sweep Accuracy Test Setup . . .	4-2
1-5. Delay Line Discriminator	1-12	4-2. Swept Frequency Endpoint and Marker Accuracy Test Setup	4-4
2-1. Location of Mainframe Parts Pertinent to Frequency Scale and RF Plug-in Installation	2-2	4-3. Frequency Stability Test Setup	4-5
2-2. Mainframe Front Panel in Open Position	2-3	4-4. 3:1 Load SWR Test Setup	4-7
2-3. RF Plug-in Latch in Release Position	2-4	4-5. Residual FM Test Setup	4-8
2-4. Operation Verification Test Setup	2-5	4-6. Residual FM Displayed on Spectrum Analyzer	4-9
3-1. Front Panel Indicator, Controls and Connectors	3-24	4-7. Crystal Detector Leveling Test Setup	4-11
3-2. Rear Panel Connectors and Switch	3-5	4-8. Power Meter Leveling Test Setup	4-13
3-3. External Crystal Detector Leveling	3-6	4-9. Internal Leveling Test Setup	4-14
3-4. Leveled RF Power Output	3-7	4-10. Power Level Attenuator Accuracy Test Setup	4-15
3-5. Unleveled RF Power Output	3-7	4-11. Harmonic Spurious Signals Test Setup	4-18
3-6. Oscillations Due to Excessive ALC Loop Gain	3-7	4-12. Harmonics with Bandpass Filters	4-20
3-7. Power Meter Leveling Operation	3-8	4-13. Nonharmonic Spurious Signals Test Setup	4-21
3-8. Internal Leveling	3-10	4-14. Residual AM Test Setup	4-23
3-9. External AM Operation	3-12	4-15. Equivalent Source SWR Test Setup	4-25
3-10. Simultaneous Transmission, Reflection Measurement Using HP Model 8755B Swept Amplitude Analyzer	3-14	4-16. Typical Pattern of a Swept SWR Measurement	4-26
3-11. External FM Operation	3-17	4-17. Conversion of Oscilloscope Trace to Source Match SWR	4-27
3-12. Spectrum Analyzer Display of Typical Frequency Modulated Waveform . . .	3-18	4-18. External FM Test Setup	4-28
3-13. Phase Lock Operation	3-19	4-19. Typical Spectrum Analyzer Display of 100 Hz Frequency Deviation	4-30

ILLUSTRATIONS (Cont'd)

Figure	Page	Figure	Page
4-20. FM Deviations at Specified Modulation Frequencies	4-31	8-12. A1 FM Driver Assembly, Component and Test Point Locations (86240C, 86235A Option 008) . .	8-14
4-21. Amplitude Modulation Test Setup	4-33	8-13. A1 FM Driver Assembly, Block Diagram (86240C, 86235A Option 008 Only)	8-15
4-22. FM Frequency Response Test Setup	4-36	8-14. A1 FM Driver Assembly, Schematic (86240C, 86235A Option 008 only)	8-15
4-23. FM Frequency Response Waveform	4-38	8-15. A2 ALC Assembly, Component and Test Point Locations	8-17
4-24. Up Converter Simulation Test Setup	4-40	8-16. A2 ALC Assembly, Block Diagram	8-18
5-1. YIG Oscillator Bias Adjustment Test Setup	5-3	8-17. A2 ALC Assembly, Schematic	8-19
5-2. YIG Driver Frequency Adjustments Test Setup	5-5	8-18. A3 YIG Driver Assembly, Component and Test Point Locations, 86235A Only	8-20
5-3. Frequency Reference Adjustments Test Setup	5-12	8-19. A3 YIG Driver Assembly, Component and Test Point Locations, 86240A/C Only	8-21
5-4. Harmonic Adjustments Test Setup	5-14	8-20. A3 YIG Driver Assembly, Component and Test Point Locations, 86240B Only	8-21
5-5. 86240A/C, 86235A Harmonics	5-16	8-21. A3 YIG Driver Assembly, Block Diagram	8-22
5-6. 86240B Harmonics Before and After Adjustment	5-18	8-22. A3 YIG Driver Assembly, Schematic	8-23
5-7. OFFSET and Power Control Adjustments Test Setup	5-19	8-23. A6 Pulse Amplifier/Bias Assembly, Component and Test Point Locations	8-24
5-8. Sample and Hold Adjustment Test Setup (Internal Leveling)	5-21	8-24. A6 Pulse Amplifier/Bias Assembly, Block Diagram	8-25
5-9. ALC Flatness Adjustment Test Setup	5-22	8-25. A6 Pulse Amplifier/Bias Assembly, Schematic	8-25
5-10. Sample and Hold Adjustment Test Setup (External Leveling Only)	5-22	8-26. A7 Motherboard Assembly, Component Locations	8-26
5-11. FM Offset Adjustment Test Setup	5-24	8-27. Overall Wiring Diagram	8-27
5-12. FM Sensitivity Adjustment Test Setup	5-25	8-28. 86235A Major Assembly and Component Locations, Top View	8-29
5-13. ALC Flatness Adjustment Test Setup	5-27	8-29. 86240A Major Assembly and Component Locations, Top View	8-29
5-14. Test Point and Adjustment Locations for 86235A Option 008 and 86240C A1 FM Assembly	5-31	8-30. 86240B Major Assembly and Component Locations, Top View	8-29
5-15. Test Point and Adjustment Locations	5-31	8-31. 86240C Major Assembly and Component Locations, Top View	8-29
6-1. Fastening Hardware, Locations and HP Part Numbers	6-25	8-32. Differences with Option 001 (Internal Leveling) Installed, Top View	8-29
8-1. RF Path Through YFO	8-1	8-33. Differences with Option 002 (70 dB Attenuator) Installed, Top View	8-29
8-2. Module-Exchange Procedure	8-3	8-34. 86235A Major Assembly and Component Locations, Bottom View	8-31
8-3. Connections to R3 POWER LEVEL Control	8-4	8-35. 86240A/B/C Major Assembly and Component Locations, Bottom View	8-31
8-4. UNLEVELED Lamp Removal and Replacement Procedure	8-5	8-36. Differences with Option 004 Installed, Bottom View	8-31
8-5. Schematic Diagram Notes	8-6	8-37. Differences with Option 004/002 Installed, Bottom View	8-31
8-6. Test Setup and Control Settings for Waveforms and Voltages on Schematic Diagrams	8-8	8-38. Test Point and Adjustment Locations	8-31
8-7. GaAs FET Amplifier	8-10		
8-8. Overall Block Diagram	8-11		
8-9. A1 FM Driver Assembly, Component and Test Point Locations (86235A, 86240A/B)	8-12		
8-10. A1 FM Driver Assembly, Block Diagram (86235A, 86240A/B)	8-13		
8-11. A1 FM Driver Assembly, Schematic (86235A, 86240A/B)	8-13		

TABLES

Table	Page	Table	Page
1-1. Specifications for 86235A/86240A/B/C Installed in 8620C	1-3	5-5. Typical Values and HP Part Numbers for A3R67	5-8
1-2. Supplemental Characteristics	1-6	5-6. Typical Values and HP Part Numbers for A3C19.	5-8
1-3. Frequency Scale Supplied	1-8	5-7. Frequency Versus Tuning Voltage	5-9
1-4. Recommended Test Equipment	1-13	5-8. 86240A Values for A3R31 and A3R53	5-10
2-1. Models 86235A/86240A/B/C Mating Connectors.	2-2	5-9. 86240B Values for A3R31 and A3R53	5-10
2-2. CW MARKER Pointer Settings.	2-6	5-10. 86240C Values for A3R31 and A3R53	5-10
3-1. Frequency Modulation Characteristics for FM-NORM-PL Switch Positions	3-3	5-11. Standard Values and HP Part Numbers for A3R31 and A3R53.	5-11
4-1. Frequency Range and Accuracy Specifications	4-2	5-12. Frequency Reference Voltage Levels.	5-13
4-2. Frequency Accuracy Test, CW Mode	4-3	6-1. Reference Designations and Abbreviations	6-2
4-3. Frequency Stability Specifications	4-5	6-2. Replaceable Parts	6-4
4-4. Power Level and Variation Specifications.	4-10	6-3. Manufacturers Code List.	6-19
4-5. Harmonic Spurious Signals Specifications.	4-17	6-4. Cables Used in 86235A.	6-20
5-1. Controls Listed in Adjustment Sequence	5-2	6-5. Cables Used in 86240A.	6-21
5-2. Factory Selected Components	5-3	6-6. Cables Used in 8640B.	6-22
5-3. Frequency End Points	5-7	6-7. Cables Used in 8620C.	6-23
5-4. Typical Values and HP Part Numbers for A3C3	5-7		

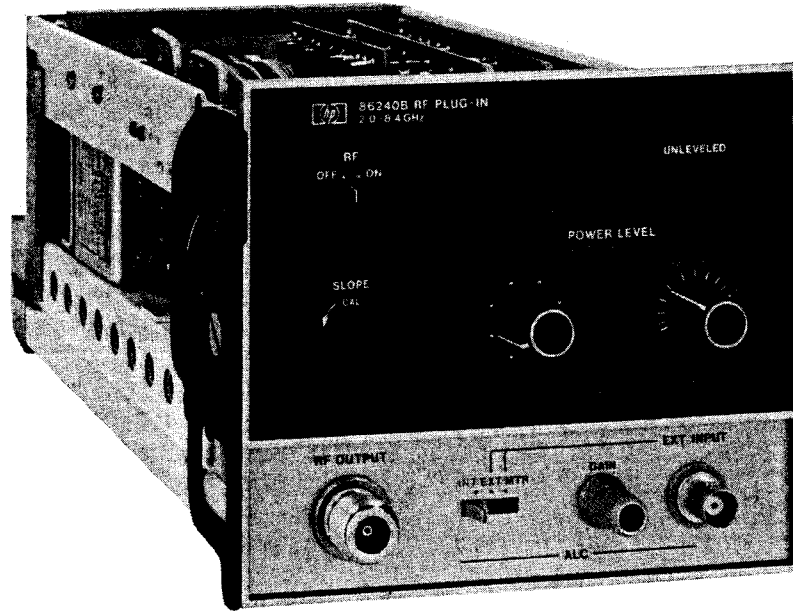

HP 86240B RF PLUG-IN

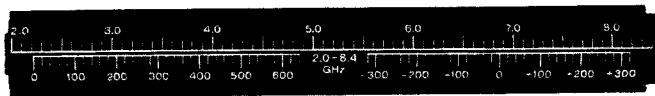

SCALE FOR 8620A AND 8620C

NOTE

The 86240B and scale are shown, however, the 86235A, 86240A/C, and scales are similar in appearance. See ACCESSORIES SUPPLIED in Section I for part number information.

Figure 1-1. RF Plug-in and Accessories Supplied

SECTION I GENERAL INFORMATION

1-1. INTRODUCTION

1-2. This Operating and Service manual contains information required to install, operate, test, adjust, and service the Hewlett-Packard Model 86235A and 86240A/B/C RF Plug-ins. Figure 1-1 shows the instrument and accessories supplied. This section covers instrument identification, description, options, accessories, specifications, and other basic information.

1-3. This manual is divided into eight sections which provide information as follows:

- a. SECTION I, GENERAL INFORMATION, contains the instrument description and specifications as well as the accessory and recommended test equipment list.
- b. SECTION II, INSTALLATION/OPERATION VERIFICATION, contains information relative to receiving inspection, preparation for use, mounting, packing, shipping, and operation verification.
- c. SECTION III, OPERATION, contains operating instructions for the instrument.
- d. SECTION IV, PERFORMANCE TESTS, contains information required to verify that instrument performance is in accordance with published specifications.
- e. SECTION V, ADJUSTMENTS, contains information required to properly adjust and align the instrument after repair.
- f. SECTION VI, REPLACEABLE PARTS, contains information required to order all parts and assemblies.
- g. SECTION VII, MANUAL BACKDATING CHANGES, contains backdating information to make this manual compatible with earlier equipment configurations.
- h. SECTION VIII, SERVICE, contains descriptions of the circuits, schematic

diagrams, parts location diagrams, and troubleshooting procedures to aid the user in maintaining the instrument.

1-4. Supplied with this manual is an Operating Information Supplement. The Supplement is a copy of the first three sections of this manual, and should be kept with the instrument for use by the operator.

1-5. Listed on the title page of this manual is a Microfiche part number. This number can be used to order 4 x 6-inch microfilm transparencies of the manual. Each microfiche contains up to 60 photoduplicates of the manual pages. The microfiche package also includes the latest Manual Changes supplement as well as all pertinent Service Notes.

1-6. SPECIFICATIONS

1-7. Instrument specifications are listed in Table 1-1. These specifications are the performance standards or limits against which the instrument is tested. Table 1-2 lists supplemental characteristics. Supplemental characteristics are not specifications but are typical characteristics included as additional information for the user.

NOTE

To insure that the RF Plug-in meets specifications listed in Table 1-1, Performance Tests (Section IV) should be performed at least every six months.

1-8. SAFETY CONSIDERATIONS

1-9. General

1-10. This product and related documentation must be reviewed for familiarization with safety markings and instructions before operation. This product has been manufactured and tested in accordance with international safety standards.

1-11. Safety Symbols



Instruction manual symbol: the apparatus will be marked with this symbol when it is necessary for the user to refer to the instruction manual in order to protect the apparatus against damage.



Indicates dangerous voltages.



Earth terminal.



The **WARNING** sign denotes a hazard. It calls attention to a procedure, practice, or the like, which, if not correctly performed or adhered to, could result in injury or loss of life. Do not proceed beyond a **WARNING** sign until the indicated conditions are fully understood and met.



The **CAUTION** sign denotes a hazard. It calls attention to an operating procedure, practice, or the like, which, if not correctly performed or adhered to, could result in damage to or destruction of part or all of the equipment. Do not proceed beyond a **CAUTION** sign until the indicated conditions are fully understood and met.

1-12. Operation

1-13. BEFORE APPLYING POWER, refer to **SAFETY CONSIDERATIONS** in Section I of the Operating and Service Manual for the mainframe.

The information, cautions, and warnings in this manual must be followed to ensure safe operation and to keep the instrument safe.



BEFORE SWITCHING ON THE INSTRUMENT, the protective earth terminal of the mainframe must be con-

ected to the protective conductor of the (mains) power cord. The mains plug should only be inserted in a socket outlet provided with protective earth contact. This protection should not be negated by using an extension cord (power cable) without a protective grounding conductor. Grounding one conductor of a two-conductor outlet is not sufficient protection.

Any interruption of the protective (grounding) conductor, inside or outside the instrument, or disconnection of the protective earth terminal could make this instrument dangerous. Whenever it is likely that this protection has been impaired, the instrument should be made inoperative and secured against any unintended operation.

BEFORE SWITCHING THE INSTRUMENT ON, ensure that all ac line powered devices connected to the instrument are connected to the protective earth ground.



BEFORE APPLYING POWER, make sure the mainframe ac input is set for the available ac line voltage, that the correct fuse is installed, and that all normal safety precautions have been taken.

1-14. Service

1-15. The information, cautions, and warnings in this manual must be followed to ensure safe operation and to keep the instrument safe. **SERVICE AND ADJUSTMENTS SHOULD BE PERFORMED ONLY BY QUALIFIED SERVICE PERSONNEL.**

1-16. Adjustment or repair of the opened instrument with the ac power connected should be avoided as much as possible but, when unavoidable, should be performed only by qualified service personnel who are aware of the hazard involved.

1-17. Capacitors inside the instrument may still be charged even though the instrument has been disconnected from its source of supply.

Table 1-1. Specifications for 86235A/86240A/B/C Installed in 8620C (1 of 3)

Specifications with RF Plug-in Installed in 8620C Sweep Oscillator Mainframe	SPECIFICATIONS			
	86235A	86240A	86240B	86240C
FREQUENCY¹				
FREQUENCY RANGE, Calibrated:	1.7 – 4.3 GHz	2.0 – 8.4 GHz	2.0 – 8.4 GHz	3.6 – 8.6 GHz
FREQUENCY ACCURACY² (at 25°C and with FM-NORM-PL switch in NORM position: CW Mode: ³ All Sweep Modes (Sweep Time >0.1 sec):	±20 MHz ±30 MHz	±20 MHz ±40 MHz	±20 MHz ±50 MHz	±20 MHz ±35 MHz
FREQUENCY STABILITY:				
With Temperature:	<±500 kHz/°C	<±500 kHz/°C	<±500 kHz/°C	<±500 kHz/°C
With 10% Line Voltage Change:	<±40 kHz	<±40 kHz	<±40 kHz	<±40 kHz
With 10 dB Power Level Change from Specified Maximum Power:	<±1.0 MHz	<±1.0 MHz	<±1.0 MHz	<±1.0 MHz
With 3:1 SWR Load Variation, All Phases:	<±250 kHz	<±250 kHz	<±250 kHz	<±250 kHz
RESIDUAL FM in 10 kHz BANDWIDTH:²				
CW Mode: FM-NORM-PL switch in NORM position:	<7 kHz peak	<9 kHz peak	<9 kHz peak	<9 kHz peak
POWER OUTPUT¹				
POWER LEVEL:^{2,9} (For calibrated frequency range at 25°C): Maximum Leveled Power:	>+16 dBm (40 mW)	>+16 dBm (40 mW)	>+13 dBm (20 mW)	>+16 dBm (40 mW)
POWER VARIATION (at specified maximum power):				
Crystal Detector Leveled (External): ^{4 7}	<±0.1 dB	<±0.1 dB	<±0.1 dB	<±0.1 dB
Power Meter Leveled (External): ^{4 5}	<±0.1 dB	<±0.1 dB	<±0.1 dB	<±0.1 dB
Internally Leveled (Option 001 or 86240B):	<±0.8 dB	<±1.0 dB	<±0.5 dB	<±0.8 dB
Calibrated Power Control Range (Internally Leveled):	10 dB	10 dB	10 dB	10 dB
POWER CALIBRATION ACCURACY:				
Internally Leveled:	±2 dB	±2 dB	±1 dB	±2 dB
Option 002 (dB/10 dB step):	±0.16 dB	±0.3 dB	±0.3 dB	±0.3 dB
EQUIVALENT SOURCE SWR:²				
Internally Leveled (Option 001 or 86240B)	<1.6	<1.6	<1.6	<1.6

Table 1-1. Specifications for 86235A/86240A/B/C Installed in 8620C (2 of 3)

Specifications with RF Plug-in Installed in 8620C Sweep Oscillator Mainframe	SPECIFICATIONS			
	86235A	86240A	86240B	86240C
POWER OUTPUT¹ (Cont'd)				
SPURIOUS SIGNALS (in dB below fundamental signal at specified maximum power unless otherwise stated):				
Harmonics:	>20 dB	>20 dB (20 mW) >16 dB (40 mW)	>45 dB	>20 dB (20 mW) >16 dB (40 mW)
Nonharmonics:	>60 dB	>60 dB	>60 dB	>60 dB
RESIDUAL AM: (AM noise in 100 kHz bandwidth): Residual AM (in dB below carrier at specified maximum power):	>50 dB	>50 dB	>50 dB	>50 dB
MODULATION¹				
EXTERNAL FM²				
FM Frequency Response (except Opt. 008): DC to 2 MHz:	±3 dB	±3 dB	±3 dB	
FM Frequency Response: ⁸ MLA-NORM Switch in MLA position:				
DC to 100 Hz:	±1.5 dB			±1.5 dB
90 kHz to 10 MHz:	±1.5 dB			±1.5 dB
MLA-NORM Switch in NORM position: DC to 10 MHz:	±1.5 dB			±1.5 dB
Maximum Deviation for Modulation Frequencies (except Opt. 008): FM-NORM-PL Switch in FM or PL position:				
DC to 100 Hz:	±75 MHz	±75 MHz	±75 MHz	
DC to 1 MHz:	±5 MHz	±5 MHz	±5 MHz	
DC to 2 MHz:	±2 MHz	±2 MHz	±2 MHz	
Maximum Deviation for Modulation Frequencies: ⁸ MLA-NORM-Switch in MLA position:				
DC to 100 Hz:	±150 MHz			±150 MHz
90 kHz to 1 MHz:	±7 MHz			±7 MHz
90 kHz to 5 MHz:	±5 MHz			±5 MHz
90 kHz to 10 MHz:	±1.5 MHz			±1.5 MHz
MLA-NORM Switch in NORM position:				
DC to 100 Hz:	±12 MHz			±12 MHz
DC to 1 kHz:	±10 MHz			±10 MHz
DC to 1 MHz:	±7 MHz			±7 MHz
DC to 5 MHz:	±5 MHz			±5 MHz
DC to 10 MHz:	±1.5 MHz			±1.5 MHz

Table 1-1. Specifications for 86235A/86240A/B/C Installed in 8620C (3 of 3)

Specifications with RF Plug-in Installed in 8620C Sweep Oscillator Mainframe	SPECIFICATIONS			
	86235A	86240A	86240B	86240C
MODULATION¹ (Cont'd)				
INTERNAL AM (Below specified maximum leveled power): 1 kHz square wave, RF Blanking, and Marker ON/OFF Ratio:	>40 dB	>40 dB	>40 dB	>40 dB
EXTERNAL AM (At specified maximum leveled power): Attenuation with +5V input:	30 dB	30 dB	30 dB	30 dB
EXTERNAL PULSE MODULATION (At specified maximum leveled power; >+6V input): ON/OFF Ratio : ⁶ Square wave symmetry: ⁶	>40 dB 40/60	>40 dB 40/60	>40 dB 40/60	>40 dB 40/60
UPCONVERTER SIMULATION:⁸				
*Across 30 MHz Sweep Width:				
**Across 50 MHz Sweep Width:	*	**		*
Linearity at 277 kHz:	≤2%	≤3.3%		≤0.5% ≤0.83%
Group Delay at 277 kHz:	≤2ns	≤3.3 ns		≤1 ns ≤1.7 ns
Differential Gain at 5.6 MHz:	≤2%	≤3.3%		≤0.5% ≤0.83%
Differential Phase at 5.6 MHz:	≤2°	≤3.3°		≤1° ≤1.7°

¹ Unless otherwise noted, all specifications are at RF OUTPUT and at 0 to 55° C.

² Supplemental characteristics are listed in Table 1-2.

³ Approach desired frequency from low-frequency end of band.

⁴ Excluding coupler and detector variation.

⁵ Use HP Model 432A/B/C power meter. Sweep Duration >10 seconds.

⁶ Specific requirements for compatibility with HP 8755A/B: ±6V, 27.8 kHz squarewave MODULATOR DRIVE output connected to PULSE IN.

⁷ Crystal Detector input to ALC EXT INPUT should be from -10 to -200 mV for specified leveling at specified power output. For use with negative polarity detectors such as HP Model 780 series Directional Detectors, and HP Models 423A/B and 424 Series Crystal Detectors.

⁸ Specification applies to upconverter versions only (86235A Option 008 or 86240C).

⁹ For Option 002, less 1 dB (power loss due to insertion loss of attenuator).

Table 1-2. Supplemental Characteristics

SUPPLEMENTAL CHARACTERISTICS				
NOTE: Values in this table are not specifications but are typical characteristics included for user information.				
FREQUENCY	86235A	86240A	86240B	86240C
FREQUENCY ACCURACY: Linearity (Correlation between frequency and SWEEP OUT voltage, Sweep Time \geq .1 sec):	$\leq \pm 4$ MHz	$\leq \pm 6$ MHz	$\leq \pm 6$ MHz	$\leq \pm 4$ MHz
Frequency Reference Output Accuracy (Nominally 1V/GHz):	$\pm .010$ V	$\pm .015$ V	$\pm .015$ V	$\pm .015$ V
CW Remote Programming: CW Frequency:	± 3.5 MHz	± 3.5 MHz	± 3.5 MHz	± 3.5 MHz
RESIDUAL FM IN 10 kHz BANDWIDTH: All MANUAL, CW, or AUTO sweep modes with FM-NORM-PL switch in FM or PL position (MLA-NORM switch in MLA position):	12 kHz peak	25 kHz peak	25 kHz peak	25 kHz peak
FREQUENCY STABILITY: DRIFT (per 10 minute interval after 1 hour warm-up):	± 200 kHz	± 200 kHz	± 200 kHz	± 200 kHz
POWER				
POWER LEVEL: Stability with Temperature Change:	± 0.1 dB/ $^{\circ}$ C	± 0.1 dB/ $^{\circ}$ C	± 0.1 dB/ $^{\circ}$ C	± 0.1 dB/ $^{\circ}$ C
Dynamic Range of POWER LEVEL Control Unleveled or Internally Leveled:	≥ 14 dB	≥ 14 dB	≥ 14 dB	≥ 14 dB
Maximum Leveled Power:	+18 dBm	+17.5 dBm	+15 dBm	+17.5 dBm
POWER VARIATION, Unleveled:	$< \pm 2$ dB	$< \pm 2$ dB	$< \pm 3$ dB	$< \pm 2$ dB
SOURCE SWR, Unleveled:	≤ 2.6	≤ 2.8	≤ 3.2	≤ 1.6
HARMONICS (in dB below fundamental signal at specified maximum power):	≥ 23 dB	≥ 21 dB	≥ 50 dB	≥ 21 dB
MODULATION				
EXTERNAL FM: Sensitivity:				
FM-NORM-PL Switch in FM or NORM:	-20 MHz/V	-20 MHz/V	-20 MHz/V	
FM-NORM-PL Switch in PL:	-6 MHz/V	-6 MHz/V	-6 MHz/V	
MLA-NORM Switch in MLA or NORM: (86240C, 86235A Option 008 Only)	+20 MHz/V			+20 MHz/V
EXTERNAL AM: Frequency Response (at maximum specified power with AM signal at EXT AM input):				
Unleveled (OFF):	> 25 kHz	> 25 kHz	> 125 kHz	> 25 kHz
Leveled:	> 125 kHz	> 125 kHz	> 125 kHz	> 125 kHz
PULSE MODULATION: Rise and Fall Time:	< 20 ns	< 20 ns	< 20 ns	< 20 ns
Minimum Pulse Width:	1 μ s	1 μ s	1 μ s	1 μ s
Minimum Pulse Delay (90% of input pulse to 90% of RF output fall):	60 ns	60 ns	60 ns	60 ns
OSCILLATOR TYPE: Fundamental. NET WEIGHT: 2.3 kg (5 lb) SHIPPING WEIGHT: 3.2 kg (7 lb) DIMENSIONS: 127 mm (5 in.) high, 295 mm (11 5/8 in.) deep, 152 mm (6 in.) wide. OUTPUT IMPEDANCE of RF OUTPUT connector: 50 ohms nominal.				

WARNING

Servicing this instrument often requires working with the instrument's protective covers removed and ac power connected. Extreme caution should be exercised since energy available at many points in the instrument may, if contacted, result in personal injury.

BEFORE SWITCHING THE INSTRUMENT ON, ensure that all ac line powered devices connected to the instrument are connected to the protective earth ground.

1-18. INSTRUMENTS COVERED BY MANUAL

1-19. Attached to the instrument is a serial number plate. (A typical serial number plate is shown in Figure 1-2.) The serial number is in two parts. The first four digits and letter are the serial number prefix; the last five digits are the suffix. The prefix is the same for all identical instruments; it changes only when a change is made to the instrument. The suffix, however, is assigned sequentially and is different for each instrument. The contents of the manual apply to instruments with the serial number prefix(es) listed under SERIAL NUMBERS on the title page.

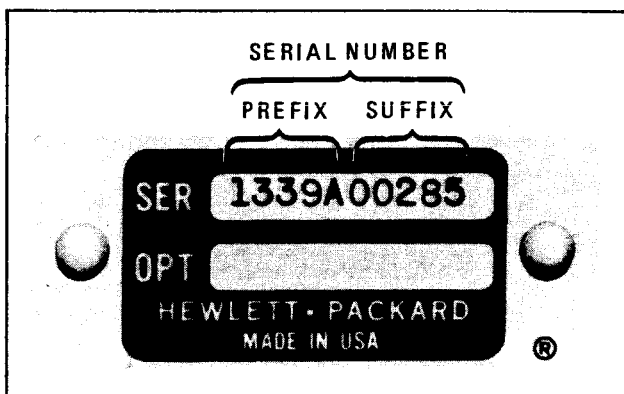

Figure 1-2. Typical Serial Number Plate

1-20. An instrument manufactured after the printing of this manual may have a serial number prefix that is not listed on the title page. This unlisted serial number prefix indicates the instrument is different from those described in this manual. The manual for this newer instrument is accompanied by a yellow Manual Changes supplement. This supplement contains "change information" that explains how to adapt the manual to the newer instrument.

1-21. In addition to change information, the supplement may contain information for correcting errors in the manual. To keep this manual as current and accurate as possible, Hewlett-Packard recommends that you periodically request the latest Manual Changes supplement. The supplement for this manual is identified with this manual's print date and part number, both of which appear on the manual's title page. Complimentary copies of the supplement are available from Hewlett-Packard.

1-22. For information concerning a serial number prefix that is not listed on the title page or in the Manual Changes supplement, contact your nearest Hewlett-Packard office.

1-23. DESCRIPTION

1-24. The 86235A and 86240A/B/C are plug-ins for the HP Model 8620-Series Sweep Oscillator mainframes. The plug-ins consist of a fundamental oscillator and associated drive circuitry for tuning. Refer to Tables 1-1 and 1-2 for complete plug-in specifications and characteristics.

1-25. The RF output of the instrument is controlled by the front-panel POWER LEVEL control. Power can be leveled, externally or internally, across the band using a conventional power sampling and feedback technique. The automatic leveling control (ALC) switch selects the mode of leveling; either external (EXT), power meter (MTR), internal (INT), or unlevelled (OFF). A front panel ALC input connector and gain control are provided to use with an external leveling loop. When the UNLEVELED Light is on, it indicates that the RF power is not level across the band. BNC connectors on the rear panel allow for external FM signal input, pulse modulation input, and frequency reference voltage output.

1-26. OPTIONS

1-27. Option 001

1-28. Option 001 provides the capability of operating in the internal power leveling mode by adding a directional coupler and detector in the RF signal path. The standard 86240B includes internal leveling capability.

1-29. Option 002

1-30. Option 002 provides a zero to 70 dB step attenuator in the RF signal path. The Option 002 RF Plug-in has two front-panel power level controls.

One control sets attenuation of the step attenuator and the other provides continuous control of the output power level.

1-31. Option 004

1-32. The Option 004 RF Plug-in has the Type N RF output connector and BNC external input on the rear panel instead of the front panel.

1-33. Option 008 (Model 86235A Only)

1-34. The Model 86235A Option 008 RF Plug-in provides compatibility with the 3700-series Microwave Link Analyzers (MLA) in the frequency range of 1.7 GHz to 4.3 GHz. The standard Model 86240C provides MLA compatibility in the frequency range of 3.6 GHz to 8.6 GHz.

1-35. EQUIPMENT REQUIRED BUT NOT SUPPLIED

1-36. To have a complete operating sweep oscillator unit, the 86235A or 86240A/B/C RF Plug-in must be installed in an 8620-Series Sweep Oscillator mainframe.

1-37. EQUIPMENT AVAILABLE

1-38. Model 8755B/182T Swept Amplitude Analyzer

1-39. The 86235A or 86240A/B/C RF Plug-in with an 8620C Sweep Oscillator mainframe is compatible with the Hewlett-Packard Model 8755A/B Swept Amplitude Analyzer. For all swept amplitude measurements, the 27.8 kHz squarewave modulation is applied directly to the RF Plug-in rear-panel PULSE IN connector. This eliminates the need for an external modulator, thus providing maximum available power to a test setup.

1-40. Power Meters and Crystal Detectors

1-41. The Hewlett-Packard Model 432A/B/C Power Meter may be used for external leveling of the RF plug-ins. External leveled power is also available using an HP 423A/B or 424-Series Crystal Detector of negative polarity. Section III contains detailed instructions for using the external power leveling systems.

1-42. Model 8410B/8411A Network Analyzer

1-43. The Model 8620C with 86235A or 86240A/B/C provides phase/gain measurement capability with the Hewlett-Packard Model 8410B Network Analyzer System. The combination of the Model 8410B Network Analyzer, the Model 8411A Frequency Converter, and an appropriate display plug-in forms a phase meter and a ratio meter for direct phase and amplitude ratio measurement on RF voltages. These measurements can be made at single frequencies and swept frequencies over full frequency range. The interfacing between the 8410B and the sweeper permits the 8410B to phase lock over the frequency range of the RF Plug-in.

1-44. Model 3700-Series Microwave Link Analyzer

1-45. The Model 8620C Sweep Oscillator with the 86235A Option 008 or 86240C RF Plug-in provides measurement capability with the Hewlett-Packard Model 3700-Series Microwave Link Analyzer (MLA).

1-46. ACCESSORIES SUPPLIED

1-47. One frequency scale is supplied with the RF Plug-in as shown in Figure 1-1. This scale is for the Model 8620A and 8620C Sweep Oscillator mainframes. Table 1-3 relates plug-in, scale frequency range, and scale part number.

Table 1-3. Frequency Scale Supplied

Plug-in	Frequency Scale	HP Part Number
86235A	1.7 – 4.3 GHz	86331-00002
86240A/B	2.0 – 8.4 GHz	86240-00028
86240C	3.6 – 8.6 GHz	86240-00029

1-48. ACCESSORIES AVAILABLE**1-49. Service Accessories**

1-50. A Service Accessories package is available for convenience in aligning and troubleshooting the mainframe and RF Plug-in. The Service Accessories package as shown in Figure 1-3, contains a plug-in extender cable, adjustment tool, and service boards. The package may be obtained from Hewlett-Packard by ordering HP Part Number 08620-60124.

1-51. Service Aids

1-52. Other service aids helpful in servicing the RF Plug-in are available and may be ordered through your nearest Hewlett-Packard office. The service aids needed specifically for servicing the 86235A and 86240A/B/C RF Plug-ins are shown in Figure 1-4.

1-53. RECOMMENDED TEST EQUIPMENT

1-54. Table 1-4 lists all of the equipment required for operation verification, (V), performance tests (P), adjustments (A), troubleshooting (T), and repair of the 86235A and 86240A/B/C RF Plug-ins. Other equipment may be substituted if it meets or exceeds the critical specifications listed in the table.

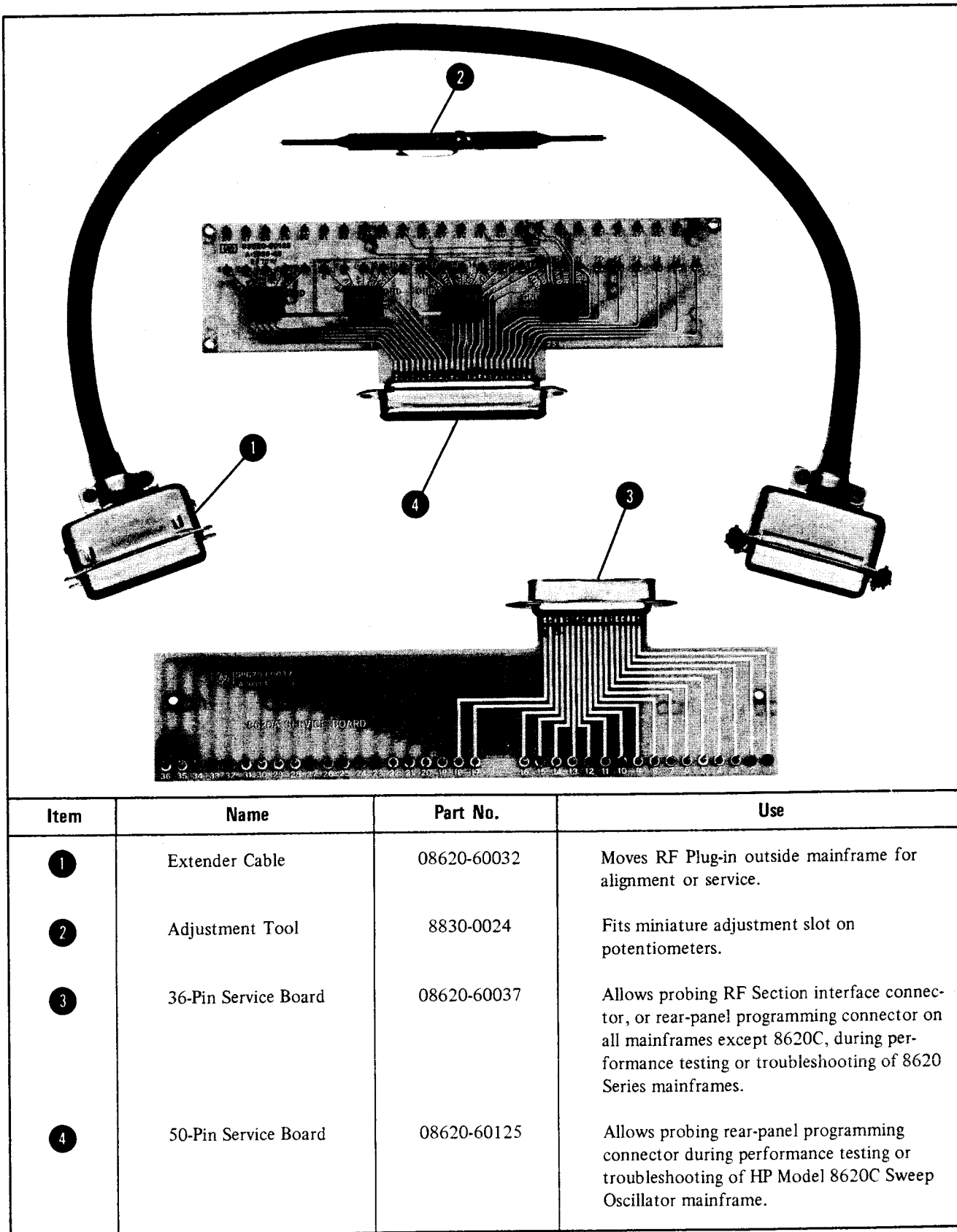

Item	Name	Part No.	Use
1	Extender Cable	08620-60032	Moves RF Plug-in outside mainframe for alignment or service.
2	Adjustment Tool	8830-0024	Fits miniature adjustment slot on potentiometers.
3	36-Pin Service Board	08620-60037	Allows probing RF Section interface connector, or rear-panel programming connector on all mainframes except 8620C, during performance testing or troubleshooting of 8620 Series mainframes.
4	50-Pin Service Board	08620-60125	Allows probing rear-panel programming connector during performance testing or troubleshooting of HP Model 8620C Sweep Oscillator mainframe.

Figure 1-3. Service Accessories, HP Part Number 08620-60124

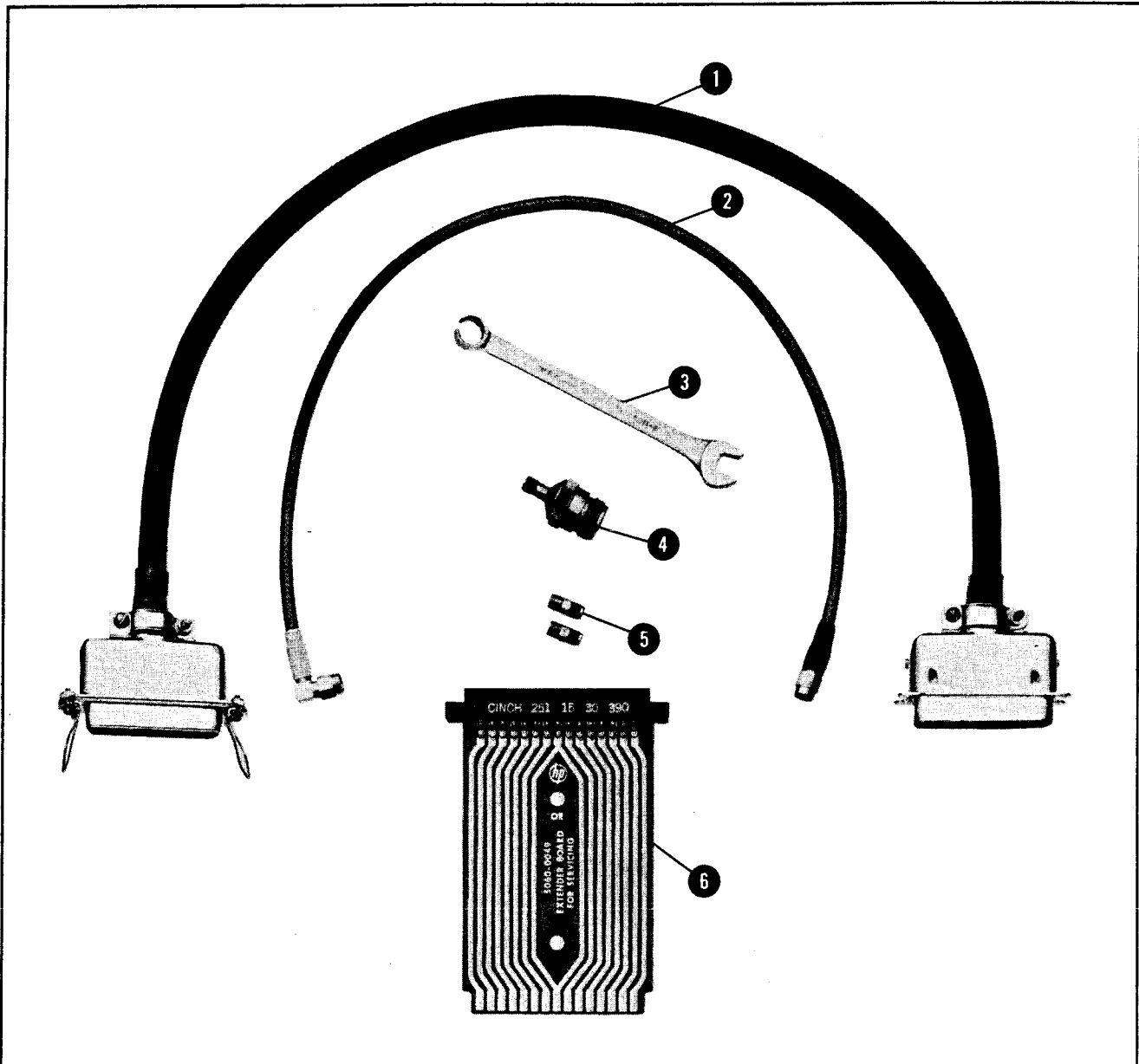

Item	Description	HP Part Number
1	Extender cable	08620-60032
2	RF service cable	8120-1578
3	Wrench, 5/16" slotted box end open end	08555-20097
4	Adapter, Type N to SMA	1250-1404
5	RF connector adapter (2), SMA jack to SMA jack	1250-1158
6	30 contact extender board (2 rows of 15 contacts)	5060-0049

Figure 1-4. Service Aids for 86235A/86240A/B/C

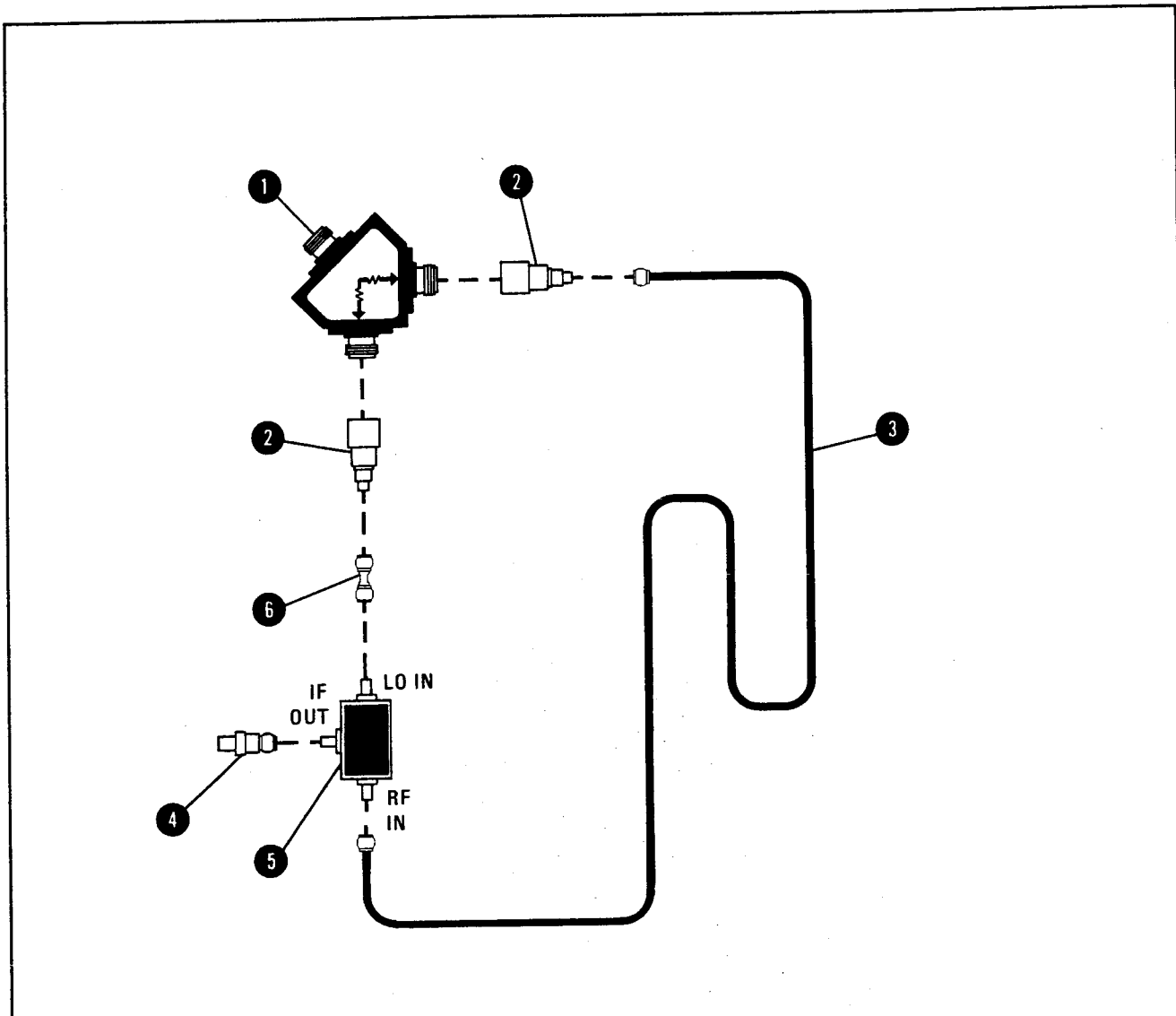

Item	Description	HP Part Number
1	Power Splitter	HP 11667A
2	Adapter: Type N Male to SMA Female (2 required)	1250-1250
3	Delay Line: > 3 feet in length, SMA male connectors	08503-20038
4	Adapter: BNC Female to Male SMA	1250-1200
5	Mixer: Double Balanced, 1 – 12 GHz RHG Electronics Part No. DM 1-12 (Refer to Table 6-3 for Address)	None
6	Adapter: SMA Male to SMA Male	1250-1159

Figure 1-5. Delay Line Discriminator

Table 1-4. Recommended Test Equipment (1 of 3)

Instrument	Critical Specifications	Recommended Model	Use*
Sweep Oscillator	No substitute mainframe	HP 8620A or 8620C	P,A,T,V
Spectrum Analyzer	Frequency Range: 1.7 GHz to 18 GHz	HP 8565A	P
Oscilloscope	Vertical Amplifier: Dual trace with 10:1 probes Bandwidth: 20 MHz minimum Vertical Sensitivity: 5 mV/Div Horizontal Sweep Rate: 1 μ s/Div minimum	HP 180C/1801A/1820C	P,A,T,V
Digital Voltmeter	Range: -50V to +50V Accuracy: $\pm 0.01\%$ Input Impedance: 10 megohms minimum	HP 3455A	A,T
Swept Amplitude Analyzer and Oscilloscope Mainframe	Frequency Range: 1.7 - 8.6 GHz	HP 8755B/182T	P,A,T
Detectors (2 required)	Frequency Response: 1.7 - 8.6 GHz Error <1.3 dB Impedance: 50 ohms	HP 11664A	P,A,T
Frequency Counter	Range: 1.7 - 8.6 GHz	HP 5340A	P,A,T,V
Function Generator	Frequency: 100 Hz - 10 MHz Output: 6V p-p into 50 ohms	HP 3312A	P,A
Power Meter and Thermistor Mount	Frequency: 1.7 - 8.6 GHz Range: +10 dBm to -20 dBm	HP 432A/8478B	P,A,V
DC Power Supply	Range: 0 to 6 Vdc Current: 0.1 Amp	HP 6214A	P,A,T
Adjustable AC Line Transformer	Output: 100 to 150 Vac Power: 150 watts	General Radio MT3A	P
Frequency Meter	Range: 1.7 to 4.0 GHz	HP 536A	P
Frequency Meter	Range: 4.0 to 8.6 GHz	HP 537A	P
Power Splitter	Frequency: 1.7 - 8.6 GHz Attenuation in each arm: 6 dB	HP 11667A	P
RMS Voltmeter	Scale: RMS volts Range: 0 to -70 dB Accuracy: $\pm 5\%$ Frequency Range: 10 Hz to 100 Hz	HP 3400A	P

Table 1-4. Recommended Test Equipment (2 of 3)

Instrument	Critical Specifications	Recommended Model	Use*
Directional Coupler (2 required)	Frequency: 1.7 – 8.6 GHz Coupling: 20 dB Directivity: >25 dB SWR all ports: <1.3 Type-N Male Connector at Input port	HP 779D	P,A
Crystal Detector (2 required)	Frequency: 1.7 – 8.6 GHz SWR: <1.7 Polarity: Negative	HP 423B	P,A,T
3 dB Attenuator	Attenuation: 3 dB±0.5 dB Frequency: 5.9 – 12.4 GHz	HP 8491A, Option 003	P
10 dB Attenuator	Attenuation: 10 dB±0.5 dB Frequency: 5.9 – 12.4 GHz	HP 8491A, Option 010	P,A,T
20 dB Attenuator	Attenuation: 20 dB±0.5 dB Frequency: 5.9 – 12.4 GHz	HP 8491A, Option 020	P,A,T,V
Adjustable Short	Frequency Range: 1.7 – 8.6 GHz	Microlab/FXR SO-6MN	P
30 Pin Extender Board	(See Figure 1-4)	HP 5060-0049	A,T
RF Service Cable	Impedance: 50 ohms Connectors: SMA to SMA (Figure 1-4)	HP 8120-1578	T
Cable	2-ft. long, BNC connectors	HP 11086A	P
Extender Cable	(See Figure 1-4)	HP 08620-60032	A,T
BNC Tee (3 required)	Connectors: BNC jack and plug	HP 1250-0781	P,A
Adjustment Tool	(See Figure 1-4)	HP 8830-0024	A
RF Connector Adapter	SMA jack to SMA jack (Figure 1-4)	HP 1250-1158	T
Delay Line Discriminator	(Refer to Figure 1-5)		P,A
Air Line (2 required)	20 cm long, APC-7 connectors	HP 11567A	P
50 ohm Termination (2 required)	50 ohms nominal	HP 11593A	P,A
Bandpass Filter	4 – 8 GHz	HP 8435A	P,A
Bandpass Filter	6 – 8 GHz	HP 8433A	P,A
Bandpass Filter	8 – 12 GHz	HP 8436A	P,A

Table 1-4. Recommended Test Equipment (3 of 3)

Instrument	Critical Specifications	Recommended Model	*Use
For 86235A Option 008 or 86240C, the following additional equipment is required:			
IF/BB Transmitter	No substitute	HP 3710A	P
BB/Transmitter (Plug-in)	No substitute	HP 3716A, Option 010	P
IF/BB Receiver	No substitute	HP 3702B	P
Differential Phase Detector (Plug-in)	No substitute	HP 3705A, Option 010	P
Down Converter	No substitute	HP 37301A	P
External LO Plug-in	No substitute	HP 3730A	P
Directional Detector	1.7 – 8.6 GHz	HP 784B	P
Sweep Oscillator	No substitute	HP 8620A or 8620C	P
RF Plug-in	1.7 – 4.3 GHz (If testing 86235A Option 008)	HP 86235A	P
RF Plug-in	3.8 – 8.6 GHz (If testing 86240C)	HP 86240A or 86240C	P
*P = Performance Test, A = Adjustments, T = Troubleshooting; V = Operation Verification			

SECTION II INSTALLATION OPERATION VERIFICATION

2-1. INTRODUCTION

2-2. This section provides installation instructions for the Model 86235A/86240A/B/C RF Plug-in and its accessories. This section also includes information about initial inspection and damage claims, preparation for using the RF Plug-in and packaging, storage and shipment.

2-3. INITIAL INSPECTION

2-4. Inspect the shipping container for damage. If the shipping container or cushioning material is damaged it should be kept until the contents of the shipment have been checked for completeness and the instrument has been checked mechanically and electrically. The contents of the shipment should be as shown in Figure 1-1. Procedures for checking electrical performance are given in Section IV. If the instrument combination does not pass the electrical performance tests, refer to the Adjustments (Section V) in this manual. If, after the Adjustments have been made, the instrument combination still fails to meet specifications, refer to mainframe Adjustment in the applicable mainframe manual. If a circuit malfunction is suspected, refer to troubleshooting procedures section of this manual or applicable mainframe manual. If the instrument does not pass the electrical tests, or if the shipment contents are incomplete, or if there is mechanical damage or defect, notify the nearest Hewlett-Packard office. If the shipping container is damaged, or the cushioning material shows signs of stress, notify the carrier as well as the Hewlett-Packard office. Keep the shipping materials for carrier's inspection. The HP office will arrange for repair or replacement without waiting for claim settlement.

2-5. PREPARATION FOR USE

2-6. Power Requirements

2-7. When the RF Plug-in is properly installed, it obtains all power through the rear interface connector from the 8620-Series Sweep Oscillator mainframe.

2-8. Interconnections

2-9. For the RF Plug-in to operate, it must be plugged into an 8620-Series mainframe. Connection is made by pushing the RF Plug-in into the mainframe so that the plug-in interface connector P1 mates with the mainframe connector.

2-10. Mating Connectors

2-11. All of the externally mounted connectors on the RF Plug-in are listed in Table 2-1. Opposite each RF Plug-in connector is an industry identification, the part number of a mating connector, and the part number of an alternate source for the mating connector.

2-12. Operating Environment

2-13. **Temperature.** The instrument may be operated in temperatures from 0°C to +55°C.

2-14. **Humidity.** The instrument may be operated in environments with humidity from 5% to 95% at 0° to 40°C. However, the instrument should also be protected from temperature extremes which cause condensation within the instrument.

2-15. **Altitude.** The instrument may be operated at altitudes up to 4572 metres (15000 feet).

2-16. Frequency Scale Installation

2-17. To install frequency scale, proceed as follows:

NOTE

If RF Plug-in is installed in mainframe, it must be removed to install frequency scale. See RF Plug-in removal instructions in paragraph 2-20.

- a. Disengage mainframe front-panel latch handle, shown in Figure 2-1, by pushing downward on handle while pushing inward lightly on top of front panel.

Table 2-1. Models 86235A/86240A/B/C Mating Connectors

86242C/86250C Connector		Mating Connector	
Connector Name	Industry Identification	Part Number	Alternate Source
J1 RF OUTPUT (FRONT) J7 RF OUTPUT (REAR)	TYPE N TYPE N	1250-0882 1250-0882	Specialty Connector 25 P117-2
J2 ALC EXT INPUT (FRONT) J5 ALC EXT INPUT (REAR)	BNC BNC	1250-0256 1250-0256	Specialty Connector 28 P118-1
J3 PULSE IN J4 FM	BNC BNC	1250-0256 1250-0256	Specialty Connector 28 P118-1
J6 FREQ REF	BNC	1250-0256	Specialty Connector 28 P118-1
P1 INTERFACE	Micro-Ribbon 36-Contact Rack and Panel Plug	1251-0484	TRW Cinch Div. 57-20360-375

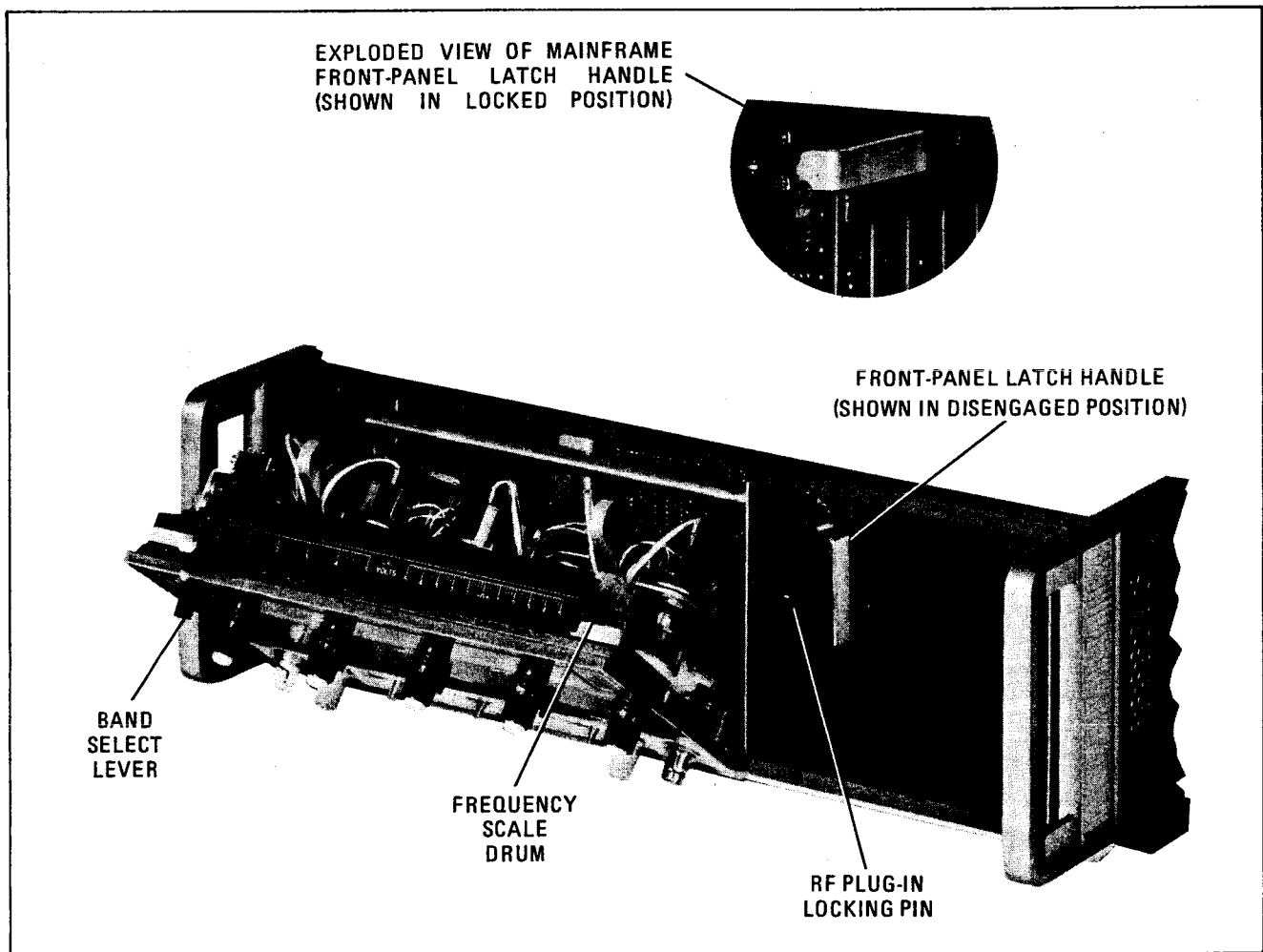

Figure 2-1. Location of Mainframe Parts Pertinent to Frequency Scale and RF Plug-in Installation

- b. Swing front panel forward and down to position shown in Figure 2-2.
- c. Depress mainframe front-panel BAND select lever, shown in Figure 2-1, to rotate frequency scale drum until desired scale position is accessible.

CAUTION

To prevent damage to frequency pointers when frequency scale drum is rotated, make certain that frequency scale is firmly in place and flush with drum edges.

NOTE

The frequency scale for the 86235A or 86240A/B/C RF Plug-in may be installed in any frequency scale drum position. If necessary to remove a frequency scale, exert a pressure OUTWARD, away from drum, on right-hand edge of scale.

- d. Insert frequency scale so key (a 1/16-inch long, 1/2 inch wide protrusion) on left end of scale fits into notch, shown in Figure 2-2, in roller on left-hand edge of drum.
- e. Push inward on right-hand edge of frequency scale to snap it in place in frequency scale drum.
- f. Return front panel to upright (closed) position, and, while pushing inward lightly on top of front panel, re-engage front-panel latch handle by pushing it upward to lock position as shown in Figure 2-1, exploded view.

2-18. RF Plug-in Installation and Removal

2-19. Installation. To install RF Plug-in, proceed as follows:

- a. If mainframe power is ON, press mainframe LINE switch to OFF position.
- b. Position latch handle located on left side of RF Plug-in so it is perpendicular to front panel. Portion of handle with rectangular cut-out should be facing forward and portion with notch should be facing rear of RF Plug-in as shown in Figure 2-3.

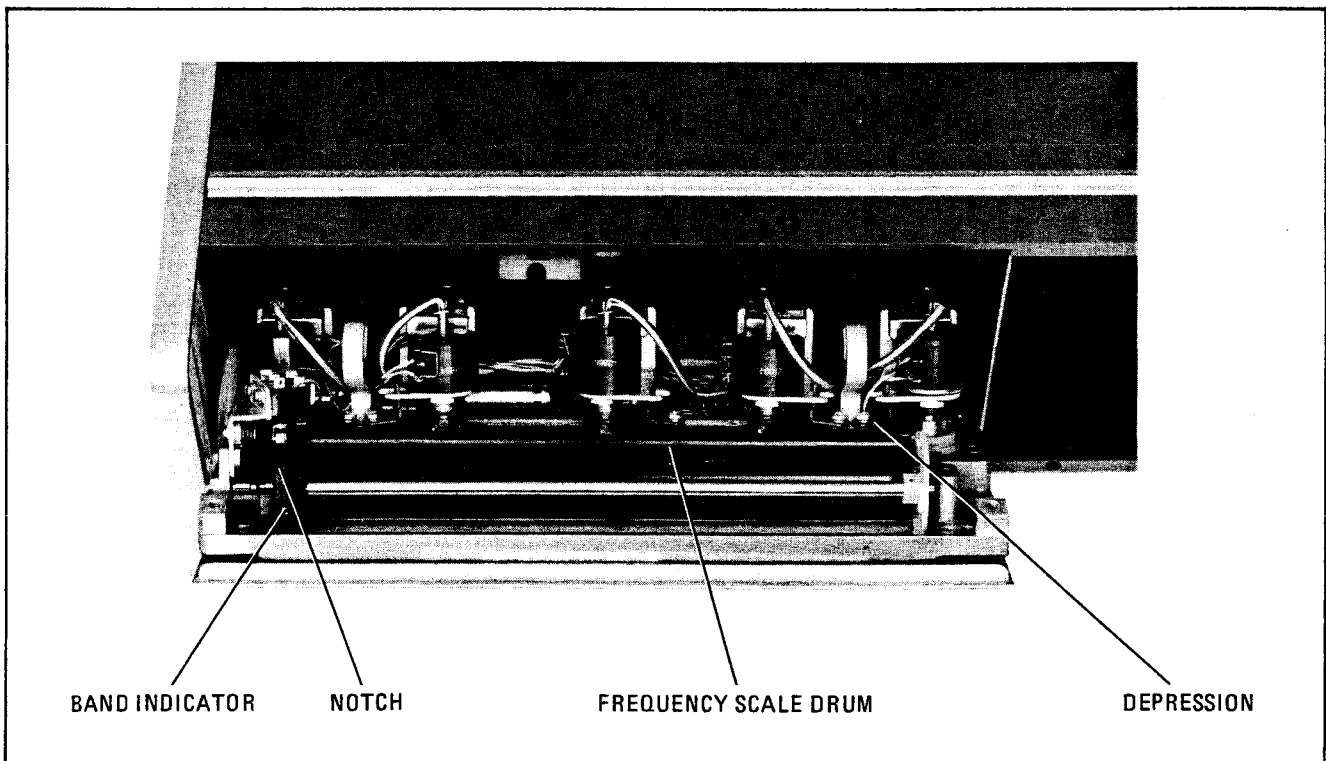

Figure 2-2. Mainframe Front Panel in Open Position

- c. Slide RF Plug-in into mainframe towards rear of compartment. RF Plug-in latch handle will engage a locking pin, shown in Figure 2-1, inside mainframe and exposed portion of latch handle will start to move downward.
- d. Push latch handle downward, while still pushing inward on RF Plug-in, until latch handle is flush with front panel.

2-20. Removal. To remove RF Plug-in, proceed as follows:

- a. Push inward on top of latch handle, shown in Figure 2-3, and pull forward and up on bottom of latch handle.
- b. When exposed portion of latch handle is in a position perpendicular to RF Plug-in front panel, it is disengaged from locking pin (Figure 2-1) and RF Plug-in may be removed by pulling forward on latch handle.

2-21. STORAGE AND SHIPMENT

2-22. Environment

2-23. The instrument may be stored or shipped in environment within the following limits:

Temperature -40°C to $+75^{\circ}\text{C}$
 Humidity 5% to 95% at 0° to 40°C
 Altitude Up to 15240 metres
 (50000 feet)

The instrument should also be protected from temperature extremes which cause condensation within the instrument.

2-24. Packaging

2-25. Original Packaging. Containers and materials identical to those used in factory packaging are available through Hewlett-Packard offices. If the instrument is being returned to Hewlett-Packard for servicing, attach a tag indicating the type of service required, return address, model number, and full serial number. Also, mark the container FRAGILE to assure careful handling. In any correspondence, refer to the instrument by model number and full serial number.

2-26. Other Packaging. The following general instructions should be used for re-packaging with commercially available materials:

- a. Wrap instrument in heavy paper or plastic. (If shipping to Hewlett-Packard Office or Service Center, attach tag indicating type of service required, return address, model number and full serial number.)
- b. Use a strong shipping container.
- c. Use enough shock-absorbing material around all sides of instrument to provide firm cushion and prevent movement inside container. Protect control panel with cardboard.
- d. Seal shipping container securely.

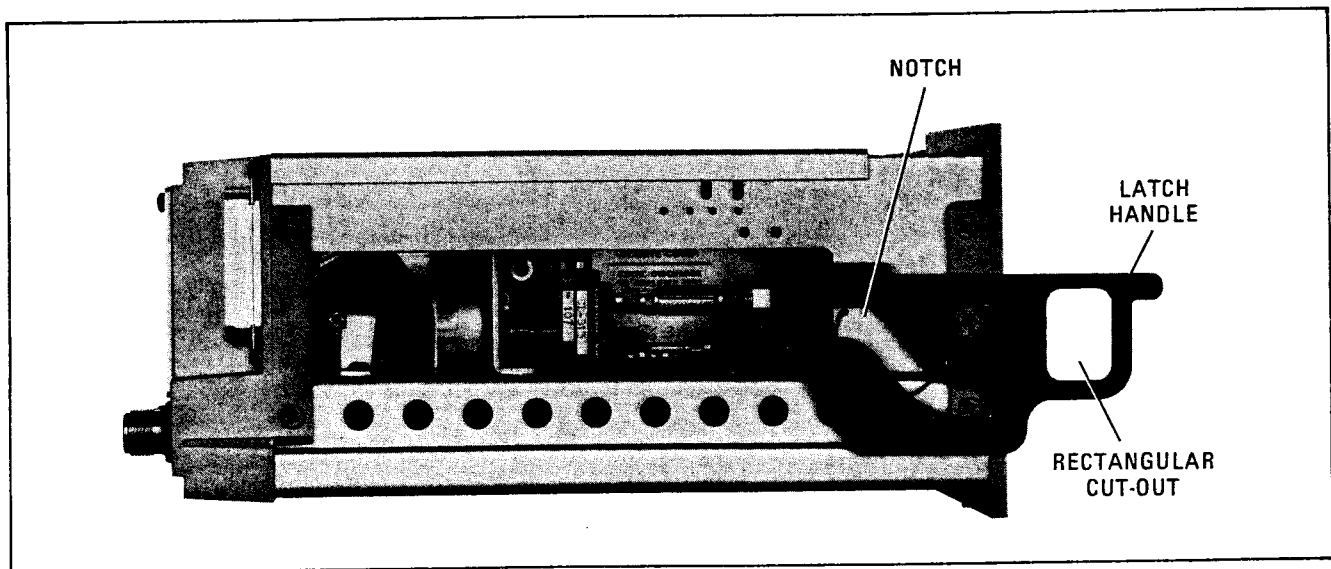

Figure 2-3. RF Plug-in Latch in Release Position

- e. Mark shipping container FRAGILE to assure careful handling.
- f. In any correspondence, refer to instrument by model number and full serial number.

2-27. OPERATION VERIFICATION

2-28. The Operation Verification Tests are designed to meet the needs of an incoming inspection. The procedures test operation of controls and

indicators and some of the critical specifications. Equipment required to perform the operation verification is listed in Table 1-4. If substitution is necessary for any of the equipment, the alternate models must meet or exceed the critical specifications listed in Table 1-4.

2-29. The Operation Verification Tests require much less time and equipment than the complete Performance Tests in Section IV. The Operation Verification Tests may also be used for verification of overall instrument operation after repair.

OPERATION VERIFICATION TESTS

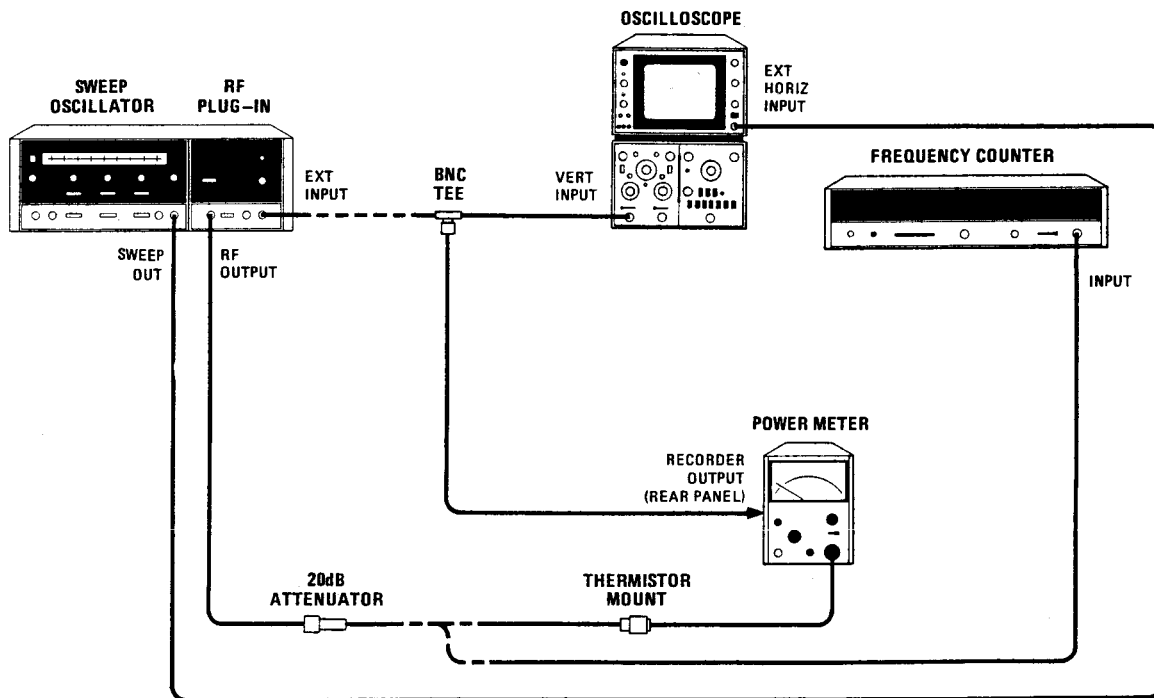

Figure 2-4. Operation Verification Test Setup

EQUIPMENT:

Sweep Oscillator	HP 8620C
Oscilloscope	HP 180C/1801A/1820C
Frequency Counter	HP 5340A
Power Meter	HP 432A
Thermistor Mount	HP 8478B
20 dB Attenuator	HP8491A,Option 020

OPERATION VERIFICATION TESTS

PROCEDURE:

1. Frequency Range and Accuracy Test:

a. Connect equipment as shown in Figure 2-4 with frequency counter connected to 20 dB attenuator and no connection to RF Plug-in EXT INPUT.

b. Set controls as follows:

8620C:

BAND..... Frequency of Plug-in installed
 CW MARKER pointer Low frequency end (see Table 2-2)
 MODE AUTO
 TIME-SECONDS1 — .01
 TIME-SECONDS Vernier Fully clockwise
 TRIGGER..... INT
 1 kHz SQ WV/OFF (rear panel) OFF
 RF BLANKING/OFF (rear panel) OFF
 DISPLAY BLANKING/OFF (rear panel) OFF

RF Plug-in:

RF OFF-ON ON
 ALC Switch..... INT or OFF
 POWER LEVEL Fully clockwise
 FM -NORM-PL NORM

c. Press 8620C LINE pushbutton to ON. Set frequency counter to measure frequency range of RF Plug-in. Press CW pushbutton and allow 30 minutes warm-up time.

NOTE

Always approach frequency settings from low-frequency end of band.

d. Frequency counter indication should be frequency at low end of band (as indicated in Table 2-2) ±20 MHz.

e. Set CW MARKER pointer to mid-band (see Table 2-2). Frequency counter indication should be frequency at mid-band (as indicated in Table 2-2) ±20 MHz.

f. Set CW MARKER pointer to high end of band (see Table 2-2). Frequency counter indication should be frequency at high end of band (as indicated in Table 2-2) ±20 MHz.

Table 2-2. CW MARKER Pointer Settings

RF Plug-in	Low End of Band (GHz)	Mid-band of Band (GHz)	High End of Band (GHz)
86235A	1.7	3.0	4.3
86240A	2.0	5.0	8.4
86240B	2.0	5.0	8.4
86240C	3.6	6.0	8.6

OPERATION VERIFICATION TESTS

2. Power Level and Variation Test:

- a. Connect equipment as shown in Figure 2-4 with BNC tee connected to EXT INPUT and thermistor mount connected to 20 dB attenuator. Set RF Plug-in ALC switch to EXT.

NOTE

For power meter leveling, sweep rates slower than 10 seconds per sweep should be used. The rate of leveling is dependent on the comparatively slow response of the thermistor mount to power level changes.

- b. Set 8620C TIME-SECONDS to 100 — 10. Press FULL SWEEP pushbutton and set power meter range to obtain meter indication in upper half of scale.
- c. Adjust RF Plug-in POWER LEVEL and ALC GAIN controls to obtain flat RF power level across the entire band as indicated on oscilloscope. (If loop oscillations occur on oscilloscope trace, turn ALC GAIN control in counterclockwise direction.)
- d. Set RF Plug-in POWER LEVEL control fully clockwise, then counterclockwise until UNLEVELED light goes out.
- e. Set mainframe MODE switch to MANUAL. Power meter indication should be >-4 dBm ($>+16$ dBm OUTPUT power) for 86235A/86240A/C, or >-7 dBm ($>+13$ dBm OUTPUT power) for 86240B.
- f. Set RF Plug-in POWER LEVEL control for power meter indication of -4 dBm ($+16$ dBm OUTPUT power) for 86235A/86240A/C, or -7 dBm ($+13$ dBm OUTPUT power) for 86240B. Turn 8620C MANUAL sweep control slowly through full range and note maximum and minimum power meter indications. Difference between maximum and minimum power meter indications should be <0.2 dB.

3. Amplitude Modulation Test:

- a. Adjust RF Plug-in POWER LEVEL control for convenient reference on power meter.
- b. Switch 1 kHz SQ WV/OFF switch (rear panel of mainframe) to SQ WV position. Power meter indication should be approximately 3 dB less than reference set in step a.

4. Press 8620C LINE pushbutton to OFF and remove RF Plug-in. Operation Verification completed.

SECTION III OPERATION

3-1. INTRODUCTION

3-2. This section explains the function of the controls and indicators of the HP Models 86235A and 86240A/B/C RF Plug-ins. It also describes typical operating modes.

3-3. PANEL FEATURES

3-4. Front and rear panel features are described in Figures 3-1 and 3-2. Description numbers match the numbers on the illustration.

3-5. OPERATING INSTRUCTIONS

3-6. Safety

3-7. BEFORE APPLYING POWER, refer to SAFETY CONSIDERATIONS in Section I of the Operating and Service manual for the mainframe.

3-8. The information, cautions, and warnings in this manual must be followed to ensure safe operation and to keep the instrument safe.

WARNING

BEFORE SWITCHING ON THE INSTRUMENT, the protective earth terminal of the mainframe must be connected to the protective conductor of the (mains) power cord. The mains plug should only be inserted in a socket outlet provided with protective earth contact. This protection should not be negated by using an extension cord (power cable) without a protective grounding conductor. Grounding one conductor of a two-conductor outlet is not sufficient protection.

Any interruption of the protective (grounding) conductor, inside or outside the instrument, or disconnection of the protective earth terminal could make this instrument dangerous. Whenever it is suspected that this protection has

been impaired, the instrument should be made inoperative and secured against any unintended operation.

BEFORE SWITCHING THE INSTRUMENT ON, ensure that all ac line powered devices connected to the instrument are connected to the protective earth ground.

CAUTION

BEFORE APPLYING POWER, make sure the mainframe ac input is set for the available ac line voltage, that the correct fuse is installed, and that all normal safety precautions have been taken.

3-9. Internal Leveling (Option 001 or Standard 86240B)

3-10. The most convenient method of RF output leveling is internal leveling. When Option 001 is installed or 86240B is used, the RF Plug-in has internal leveling capability, providing leveled power at the output port.

3-11. In the internal leveling mode, a directional detector senses the RF level at the output of the oscillator and applies the detected dc voltage to the automatic leveling control (ALC) circuit.

3-12. External Crystal Detector Leveling

CAUTION

Do not exceed maximum input level of ± 1 Vdc.

3-13. External leveling using a directional detector or directional coupler and crystal detector, provides leveled RF power near the point of measurement. In this leveling system, the coupler samples the RF Output signal and the detector produces a dc voltage proportional to the RF Output signal. The dc voltage from the detector is applied, through the RF Plug-in front-panel ALC EXT IN-

PUT connector, to the ALC circuitry where it is used to provide a correction signal to the PIN Modulator to control the RF Output level. For best operation the dc voltage supplied by the crystal detector should be between -10 and -200 mV. The ALC circuitry is designed for use with negative polarity crystal detectors.

3-14. External Power Meter Leveling

CAUTION

Do not exceed maximum input level of ± 4 Vdc.

3-15. External leveling can also be accomplished using a directional coupler and a power meter. In this leveling system, the coupler samples the RF output signal and applies it to the power meter. The power meter produces a dc voltage (RECORDER OUTPUT) which is applied, through the RF Plug-in front-panel ALC EXT INPUT connector, to the ALC circuitry. Front-panel ALC switch must be in MTR (Meter) position.

3-16. External AM

3-17. The RF Output signal can be amplitude modulated using a linear modulating signal applied through mainframe rear-panel EXT AM connector or square wave modulating signal applied through RF Plug-in rear-panel PULSE IN connector. External amplitude modulation is possible in all operating modes. Square wave modulation capability through RF Plug-in PULSE IN connector meets the specific requirements for compatibility with the HP Model 8755B Swept Amplitude Analyzer.

3-18. External FM

CAUTION

Do not exceed maximum input level of ± 12 Vdc.

3-19. The RF output signal can be frequency modulated using an external modulating signal applied through the FM connector. The external FM function provides a means of obtaining an

output frequency that varies under the control of an external modulation signal. A positive-going voltage causes output frequency to decrease. For 86235A Option 008 and 86240C (MLA Up converters), a positive-going voltage causes output frequency to increase. Rear-panel selector switch S3 selects mode of FM operation. Refer to Paragraph 3-23.

3-20. Phase Lock Operation (Not Available in RF Plug-ins with MLA Compatibility)

3-21. The RF output (CW) signal may be phase-locked using an external phase-lock signal applied through the FM connector. The phase-lock function provides a means of obtaining a very stable CW frequency by transferring the frequency stability of a reference oscillator to the RF Plug-in. If the CW frequency starts to drift, the phase difference between the CW frequency and the reference frequency (reference oscillator) is detected, and a dc correction voltage is applied to restore the CW frequency to its previous point. Stability of this CW frequency is determined by the stability of the reference oscillator. Rear-panel selector switch S3 selects either FM or PL (phase-lock) mode of operation. Refer to Paragraph 3-23.

3-22. A sweep signal output is available at the rear-panel FREQ REF connector. This signal may be used for phase-locking external equipment. The sweep signal is approximately 1V/GHz.

3-23. FM-NORM-PL Switch

3-24. Rear-panel selector switch S3, Figure 3-2, selects the mode of operation for input signal to rear-panel FM connector. In FM position, the input signal is applied to both the main and FM coils of the YIG Tuned Oscillator. Modulating frequencies up to 2 MHz may be used to provide frequency deviations up to ± 75 MHz (at low modulation frequencies). In NORM position, the CW filter is switched in to provide for less residual FM. In PL position, the input signal is applied to both coils of the YIG Tuned Oscillator to provide phaselocking. The 86235A Option 008 and 86240C have no PL position for switch S3 (MLA-NORM). Table 3-1 relates the switch positions and external FM characteristics.

3-25. Operator's Maintenance — Fuses

3-26. Power circuits in the 86235A and 86240A/B/C are fused in the mainframe. Supplies in the 8620Series mainframe that are used to power the plug-in are +5 V, +20 V, -10V and -40V. See the mainframe Operating and Service Manual for fuse replacement.

3-27. The 86235A has a 0.5 ampere fuse (A7F1) on the bottom of the Motherboard Assembly to protect the +10V regulated supply. A7F1 is manufactured by Bussman (Type GMW-1/2; HP Part Number 2110-0046). The 86240A/B/C uses the same fuse for A7F1 and also has a 0.3 ampere fuse (A4A1F1) that provides protection for the YIG FM coil. A4A1F1 is also manufactured by Bussman (GMW 3/10; HP Part Number 2110-0331).

Table 3-1. Frequency Modulation Characteristics for FM-NORM-PL Switch Positions

External FM Characteristic	Switch Positions				
	FM (MLA)		NORM		PL
	86235A 86240A/B	86235A, Opt. 008 86240C	86235A 86240A/B	86235A, Opt. 008 86240C	86235A 86240A/B
Sensitivity	-20 MHz/V	+20 MHz/V	-20 MHz/V	+20 MHz/V	-6 MHz/V
Maximum Deviation	±75 MHz	±150 MHz	±75 MHz	±12 MHz	±25 MHz (typical)
Residual FM	<12 kHz peak for 86235A	<12 kHz peak for Opt. 008	<4 kHz peak for 86235A	<4 kHz peak for Opt. 008	<12 kHz peak for 86235A
	<25 kHz peak for 86240A/B	<25 kHz peak for 86240C	<5 kHz peak for 86240A/B	<5 kHz peak for 86240C	<25 kHz peak for 86240A/B

FRONT PANEL FEATURES

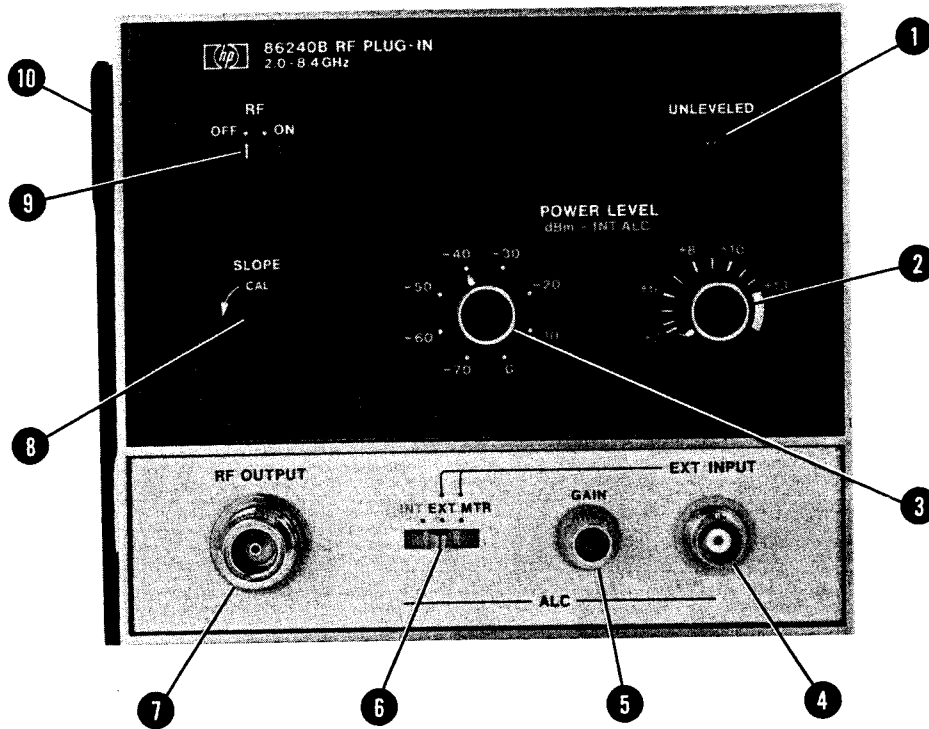

- ① **UNLEVELED lamp.** Lights when plug-in is not in an automatic leveling mode or when in a leveling mode and RF output is not level across band.
- ② **POWER LEVEL control.** Adjusts RF power output. Clockwise rotation increases power output.
- ③ **POWER LEVEL (10 dB/step) control.** Adjusts RF power output in 10 dB steps (Option 002 only).
- ④ **ALC EXT INPUT BNC connector.** Input, for external leveling, from crystal detector or power meter.

NOTE
When Option 004 is installed, EXT ALC IN connector is on rear panel. (See Figure 3-2.)

- ⑤ **ALC GAIN control.** Adjusts external leveling gain when using external leveling. Clockwise rotation increases gain.
- ⑥ **ALC switch.** Selects EXT (external leveling), MTR (Power meter leveling), or INT (internal leveling).

NOTE

When internal leveling is not installed, ALC switch selects either EXT (external), or MTR (power meter leveling), or OFF (no leveling).

- ⑦ **RF OUTPUT connector.** Type-N 50 ohm RF output connector.

NOTE

When Option 004 is installed, RF OUT connector is on rear panel. (See Figure 3-2.)

- ⑧ **SLOPE control.** Compensates for external RF cable response when internally leveling (internal leveling only).
- ⑨ **RF ON-OFF switch.** Turns RF power on and off. This is useful when zeroing a power meter.
- ⑩ **Drawer Latching Handle.** Aids in installing and removing RF Plug-in. After installing, handle locks to hold RF Plug-in in place.

Figure 3-1. Front Panel Indicator, Controls and Connectors

REAR PANEL FEATURES

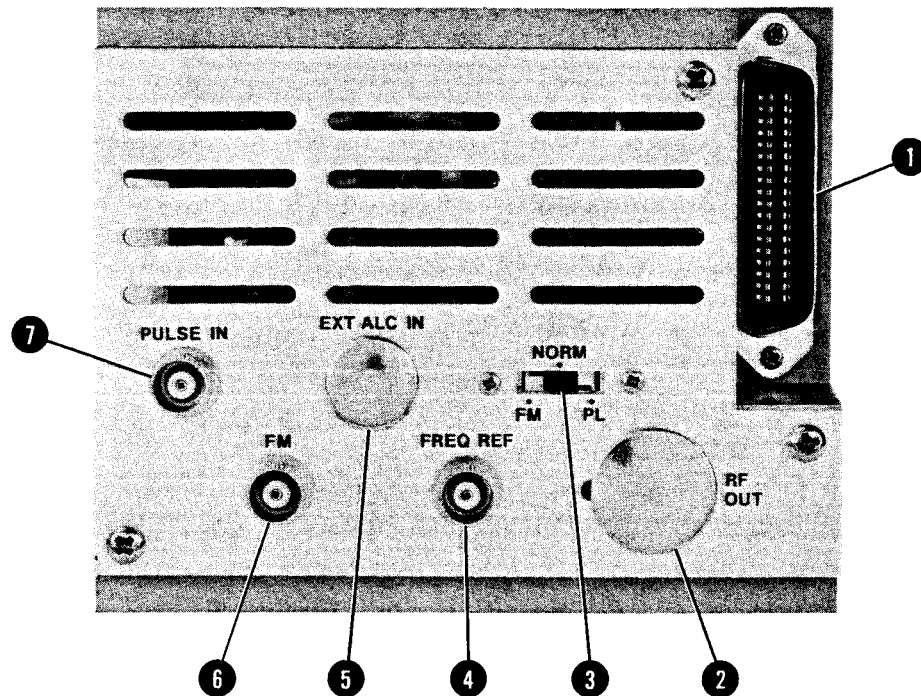

- 1 **Interface Connector.** Provides interconnections between mainframe and RF Plug-in.
- 2 When Option 004 is installed, RF output connector is mounted on rear panel and lower front panel is different.
- 3 **FM-NORM-PL (MLA-NORM) switch.** Operates in conjunction with FM input connector to provide optimum performance for either normal sweep (NORM), frequency modulation (FM), or phase lock (PL) operation. If FM or PL modes of operation are not being used, switch should be in NORM. For 86235A Option 008 and 86240C, this switch has only two positions and is labeled MLA-NORM.
- 4 **FREQ REF BNC connector.** Provides approximately 1V/GHz sweep signal output.
- 5 When Option 004 is installed, external ALC input connector is mounted on rear panel and lower front panel is different.
- 6 **FM BNC connector.** Input connector for frequency modulation signal or phase-locking error signal.
- 7 **PULSE IN connector.** Provides input port for external pulse or square wave modulation. Provides 8755 compatibility.

NOTE

The 86240B is shown, however the 86235A and 86240A/C are similar in appearance.

Figure 3-2. Rear Panel Connectors and Switch

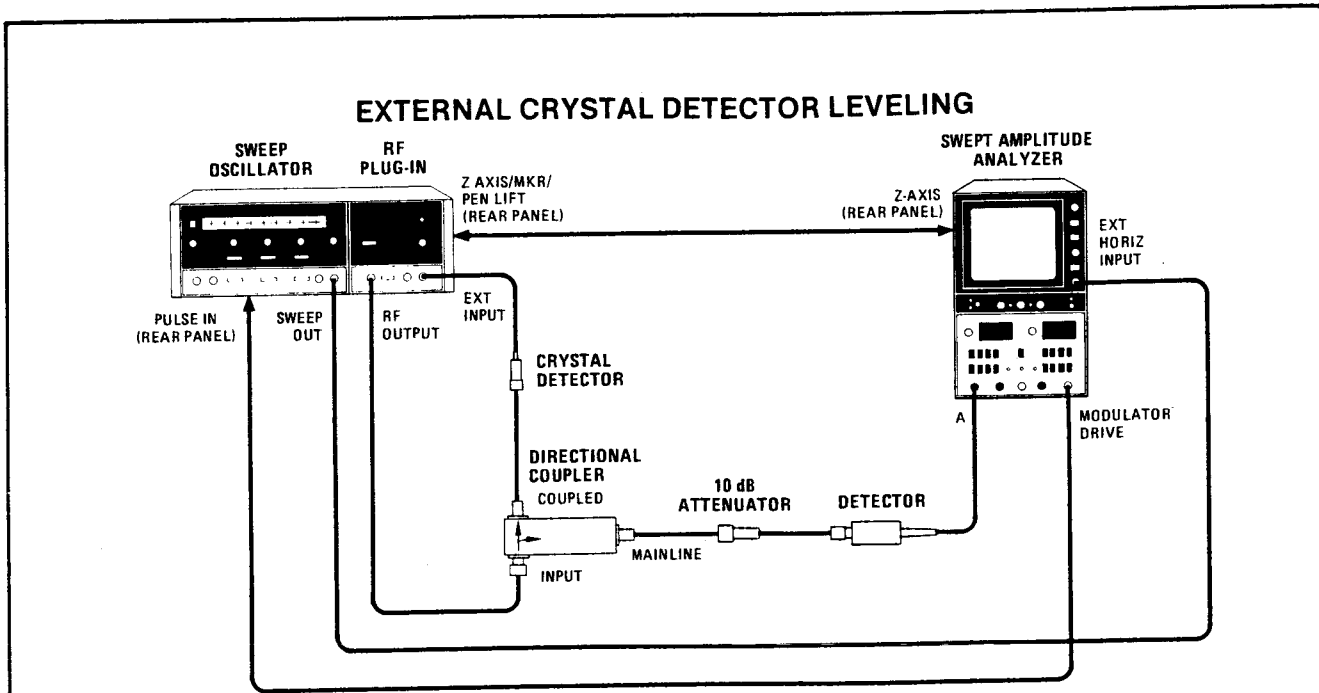

EQUIPMENT:

Sweep Oscillator	HP 8620C
RF Plug-in	HP 86235A or HP 86240A/B/C
Swept Amplitude Analyzer	HP 8755B/182T
Detector	HP 11664A
10 dB Attenuator	HP 8491A, Option 010
Directional Coupler	HP 779D

PROCEDURE:

1. Connect equipment as shown in test setup above.

NOTE

The 86235A and 86240A/B/C RF Plug-ins are designed for use with negative (-) output crystals. These instruments will not function properly using positive (+) output crystals.

2. Set controls as follows:

8620C:

BAND	Frequency of Plug-in installed
MARKERS	OFF
MODE	AUTO
TRIGGER	INT
TIME-SECONDS1 — .01
TIME-SECONDS Vernier	Fully clockwise
1 kHz SQ WV/OFF (rear panel)	OFF
RF BLANKING/OFF (rear panel)	RF BLANKING
DISPLAY BLANKING/OFF (rear panel)	DISPLAY BLANKING

Figure 3-3. External Crystal Detector Leveling (1 of 2)

EXTERNAL CRYSTAL DETECTOR LEVELING

RF PLUG-IN:

RF OFF-ON ON
 POWER LEVEL Fully clockwise
 ALC switch EXT
 ALC GAIN..... Fully clockwise

3. Press 8620C LINE switch to ON; LINE and FULL SWEEP pushbuttons should light. Allow 30 minutes warm-up time.
4. Adjust RF Plug-in ALC GAIN and POWER LEVEL controls fully clockwise for maximum RF power and maximum external preamplifier gain. One of the conditions shown in Figures 3-4, 3-5, or 3-6 should be displayed on 8755B. If trace is unlevel, as shown in Figure 3-5, or just partially leveled and UNLEVELED light is on, turn POWER LEVEL control counterclockwise to reduce power output until trace is level across band as shown in Figure 3-4. If external preamplifier gain is too high, oscillations may occur as shown in Figure 3-6. To remove oscillations, reduce external preamplifier gain by turning RF Plug-in ALC GAIN control counterclockwise.

Figure 3-3. External Crystal Detector Leveling (2 of 2)

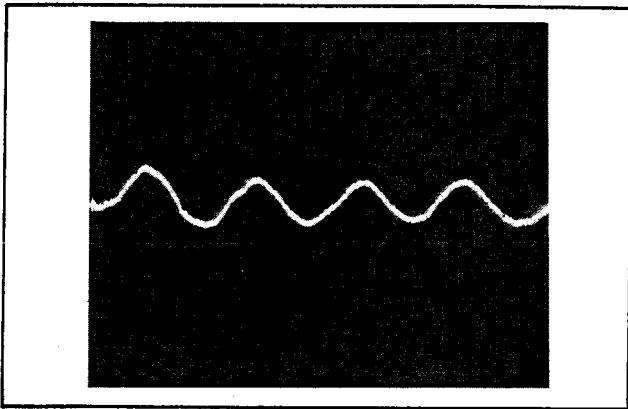

Figure 3-4. Leveled RF Power Output

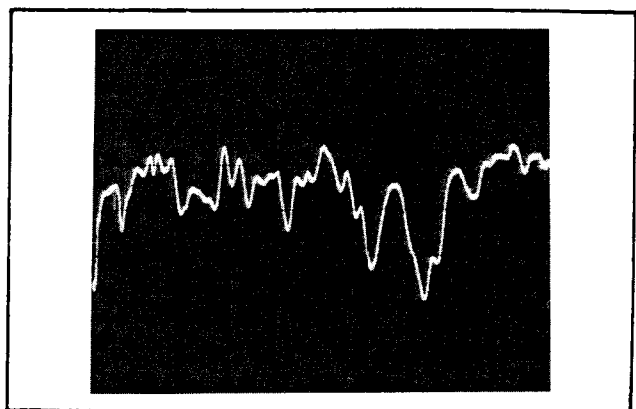

Figure 3-5. Unlevelled RF Power Output

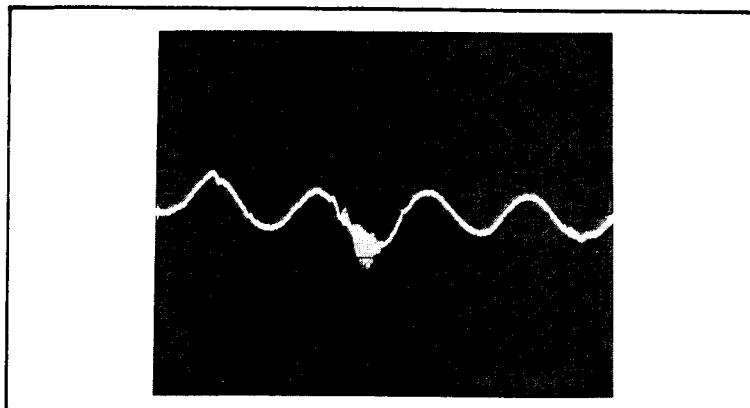
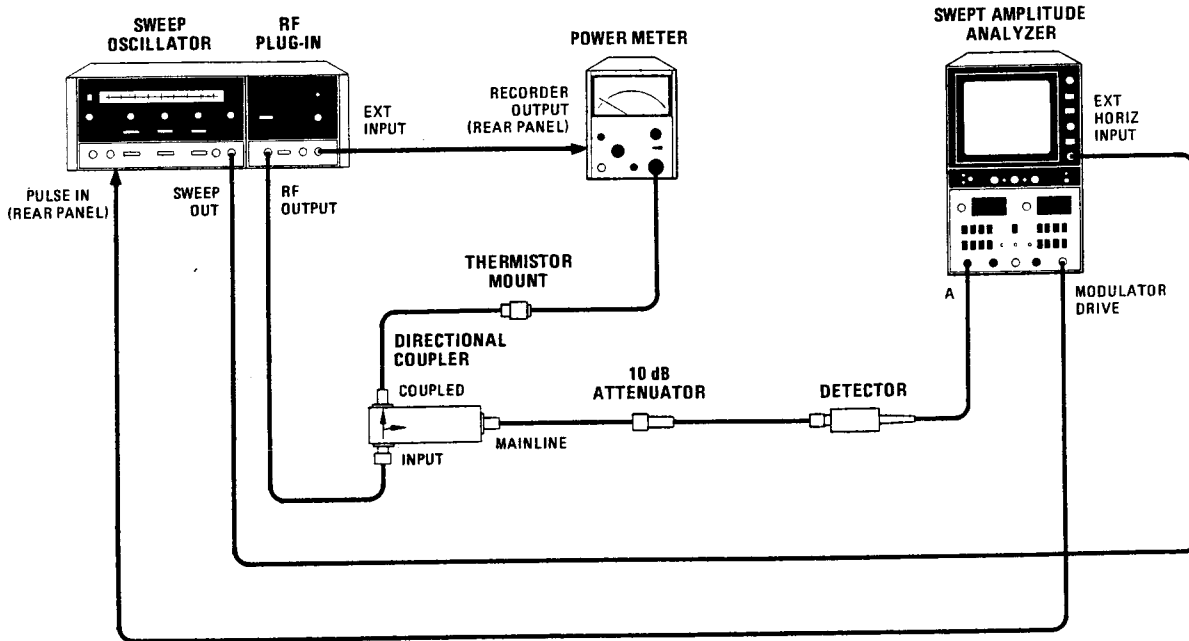

Figure 3-6. Oscillations Due to Excessive ALC Loop Gain

POWER METER LEVELING



EQUIPMENT:

Sweep Oscillator	HP 8620C
RF Plug-in	HP 86235A or HP 86240A/B/C
Swept Amplitude Analyzer	HP 8755B/182T
Power Meter	HP 432A
Thermistor Mount	HP 8478B
Detector	HP 11664A
10 dB Attenuator	HP 8491A, Option 010
Directional Coupler	HP 779D

NOTE

Power meter leveling should use the slowest sweep rate because of the slow response time of the thermistor mount.

PROCEDURE:

1. Connect equipment as shown in test setup above.

Figure 3-7. Power Meter Leveling Operation (1 of 2)

POWER METER LEVELING

2. Set controls as follows:

8620C:

BAND Frequency of Plug-in installed
 MARKERS OFF
 MODE AUTO
 TRIGGER INT
 TIME-SECONDS 100 – 10
 TIME-SECONDS Vernier Fully clockwise
 1 kHz SQ WV/OFF (rear panel) OFF
 RF BLANKING/OFF (rear panel) OFF
 DISPLAY BLANKING/OFF
 (rear panel) DISPLAY BLANKING

RF PLUG-IN:

RF OFF-ON ON
 POWER LEVEL Fully clockwise
 ALC switch MTR
 ALC GAIN Fully clockwise

3. Press 8620C LINE switch to ON; LINE and FULL SWEEP pushbuttons should light. Allow 30 minutes warm-up time.
4. Adjust power meter range to obtain an indication near top 1/3 of meter deflection range.
5. One of the conditions shown in Figures 3-4 through 3-6 should be displayed on 8755B. These displays will vary depending on directinal coupler frequency response. If trace is unlevelled as shown in Figure 3-5, turn POWER LEVEL control counterclockwise to reduce power output until trace is level across band as shown in Figure 3-4. If loop gain is too high, oscillations may occur as shown in Figure 3-6. To remove oscillations, reduce gain by turning ALC GAIN control counterclockwise.

Figure 3-7. Power Meter Leveling Operation (2 of 2)

INTERNAL LEVELING (OPTION 001 OR STANDARD 86240B)

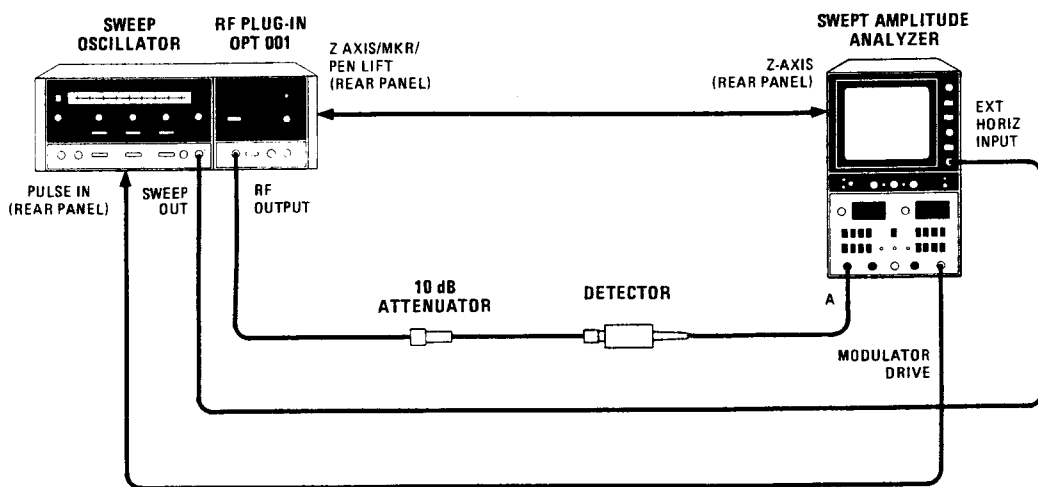

EQUIPMENT:

- Sweep Oscillator HP 8620C
- RF Plug-in HP 86235A Option 001,
86240A/C Option 001, or 86240B
- Swept Amplitude Analyzer HP 8755B/182T
- Detector HP 11664A
- 10 dB Attenuator..... HP 8491A, Option 010

PROCEDURE:

1. Connect equipment as shown above.

NOTE

The RF Plug-in must have an internal directional detector to operate in an internal leveling mode.

2. Set controls as follows:

- 8620C:
- BAND Frequency of Plug-in installed
 - MARKERS OFF
 - MODE AUTO
 - TRIGGER INT
 - TIME-SECONDS1 — .01
 - TIME-SECONDS Vernier Fully clockwise
 - 1 kHz SQ WV/OFF (rear panel) OFF
 - RF BLANKING/OFF (rear panel) RF BLANKING
 - DISPLAY BLANKING/OFF (rear panel) DISPLAY BLANKING

Figure 3-8. Internal Leveling (1 of 2)

INTERNAL LEVELING (OPTION 001 OR STANDARD 86240B)

RF PLUG-IN:

RF OFF-ON ON
POWER LEVEL Fully clockwise
ALC switch INT
ALC GAIN Fully clockwise
SLOPE CAL

3. Press 8620C LINE Pushbutton switch to ON; LINE and FULL SWEEP pushbuttons should light. Allow 30 minutes warm-up time.
4. From fully clockwise position, slowly adjust POWER LEVEL control counterclockwise until UNLEVELED lamp goes out. This is adjustment point for maximum leveled power. 8755B trace should be leveled as shown in Figure 3-4. Adjust SLOPE control for best flatness.

Figure 3-8. Internal Leveling (2 of 2)

EXTERNAL AMPLITUDE MODULATION

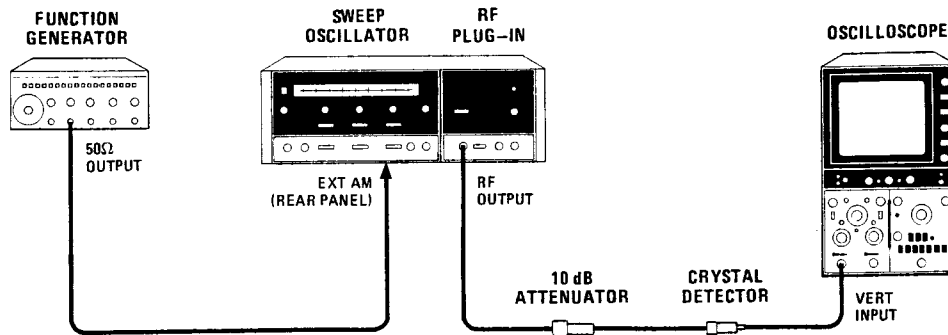

EQUIPMENT:

- Sweep Oscillator HP 8620C
- RF Plug-in HP 86235A or HP 86240A/B/C
- Oscilloscope HP 180C/1801A/1820C
- Function Generator HP3312A
- Crystal Detector (Negative polarity) HP 423B
- 10 dB Attenuator HP 8491A, Option 010

PROCEDURE:

1. Connect equipment as shown in test setup above.
2. Set controls as follows:

8620C:

- CW MARKER pointer (white) Frequency desired
- MARKERS OFF
- 1 kHz SQ WV/OFF (rear panel) OFF
- RF BLANKING/OFF (rear panel) OFF
- DISPLAY BLANKING/OFF (rear panel) OFF

RF PLUG-IN:

- RF OFF-ON ON
- POWER LEVEL Fully clockwise
- ALC switch OFF or INT
- ALC GAIN Fully counterclockwise

Figure 3-9. External AM Operation (1 of 2)

EXTERNAL AMPLITUDE MODULATION

3. Press 8620C LINE switch to ON. Press CW pushbutton. Allow 30 minutes warm-up time.
4. Set oscilloscope for internal sweep and vertical sensitivity of 20 mV/div. Establish zero volt baseline near top graticule of oscilloscope.
5. Set amplitude modulation source for modulating frequency of 1 kHz (sine wave) and voltage output of 0 Vrms.
6. Set RF Plug-in POWER LEVEL control fully clockwise and note dc output of crystal detector on oscilloscope.
7. Using RF Plug-in POWER LEVEL control, decrease crystal detector output to one-third dc value noted in step 6. Adjust oscilloscope vertical controls for convenient display of this dc level.

NOTE

Amplitude modulation will appear on oscilloscope as a periodic waveform with same repetition rate as external modulation frequency.

8. Increase output voltage from amplitude modulation source until amplitude modulation is displayed on oscilloscope.

NOTE

When using 8755A/B, pulse, or square wave modulation, connect external modulation source to PULSE IN connector (rear of RF Plug-in).

Figure 3-9. External AM Operation (2 of 2)

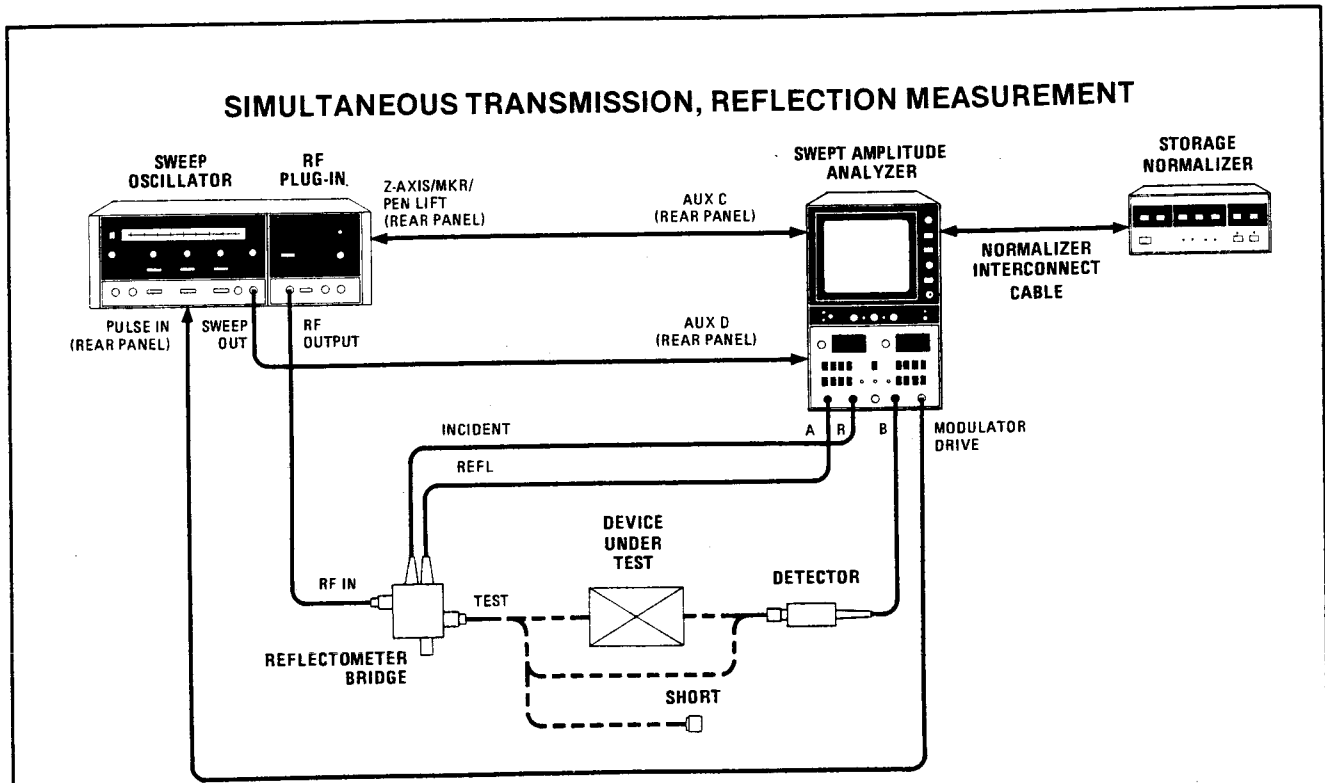

EQUIPMENT:

Sweep Oscillator	HP 8620C
RF Plug-in	HP 86235A or HP 86240A/B/C
Swept Amplitude Analyzer	HP 8755B/182T
Storage-Normalizer	HP 8750A
Detector	HP 11664A
Reflectometer Bridge	HP 11666A
Type N Male Short	HP 11512A
Normalizer Interconnect Cable	HP 08750-60014

NOTE

The HP 11666A Reflectometer Bridge may generate harmonics which appear to increase the harmonic spurious signals in the 86240B beyond the specification.

PROCEDURE:

1. Connect equipment as shown in test setup above. Connect Type N Short to 11666A test port.
2. Set controls as follows:

8620C:

CW MARKER pointer	Center-scale
MARKERS	OFF
1 kHz SQ WV/OFF (rear panel)	OFF

Figure 3-10. Simultaneous Transmission, Reflection Measurement Using HP Model 8755B Swept Amplitude Analyzer (1 of 3)

SIMULTANEOUS TRANSMISSION, REFLECTION MEASUREMENT

RF BLANKING/OFF (rear panel) OFF
 DISPLAY BLANKING/OFF
 (rear panel) DISPLAY BLANKING

RF PLUG-IN:

RF OFF-ON ON
 ALC switch OFF or INT
 ALC GAIN Fully counterclockwise
 POWER LEVEL Fully counterclockwise

3. Press 8620C LINE pushbutton switch ON. allow 30 minutes warm-up time.
4. Press ΔF pushbutton and set ΔF control fully counterclockwise.

NOTE

The 8750A Storage-Normalizer and 8755B/182T Swept Amplitude Analyzer must be matched according to the procedure in Section III of the 8750A Operating and Service Manual (HP Part No. 08750-90006).

5. Turn off 8755B CHANNEL 2 display by pressing one of the CHANNEL 2 DISPLAY pushbuttons part way in to "pop" out all of the CHANNEL 2 DISPLAY pushbuttons.
6. Press 8750A BYPASS pushbutton. Set 8755B CHANNEL 1 VERNIER ON/OFF switch to OFF and set CHANNEL 1 REFERENCE LEVEL thumbwheels to -00 dB.
7. Press 8755B CHANNEL 1 DISPLAY REFERENCE POSITION pushbutton and adjust REFERENCE POSITION screwdriver adjustment to place CRT trace on center graticule line.
8. Press 8755B CHANNEL 1 DISPLAY A pushbutton and adjust RF plug-in POWER LEVEL to place the CRT trace on center graticule line.
9. Press 8755B CHANNEL 1 DISPLAY A/R pushbutton and set VERNIER ON/OFF switch to ON. Select dB/DIV resolution desired for reflection measurement and adjust CHANNEL 1 VERNIER control to place CRT trace on center graticule line.
10. Press 8750A CH 1 and INPUT pushbuttons to select CHANNEL 1 display. Normalize CRT display by pressing 8750A STORE INPUT then INPUT -MEM pushbuttons. Center graticule line now represents 0 dB return loss.
11. Remove Type N short and connect 11664A Detector to 11666A TEST port.

Figure 3-10. Simultaneous Transmission, Reflection Measurement Using HP Model 8755B Swept Amplitude Analyzer (2 of 3)

SIMULTANEOUS TRANSMISSION, REFLECTION MEASUREMENT

12. Press 8750A BYPASS pushbutton. Turn off 8755B CHANNEL 1 display by pressing one of the CHANNEL 1 DISPLAY pushbuttons part way in to "pop" out all of the CHANNEL 1 DISPLAY pushbuttons.
13. Set 8755B CHANNEL 2 VERNIER ON/OFF switch to OFF and set CHANNEL 2 REFERENCE LEVEL thumbwheels to -00 dB.
14. Press 8755B CHANNEL 2 DISPLAY REFERENCE POSITION pushbutton and adjust REFERENCE POSITION screwdriver adjustment to place CRT trace on center graticule line.
15. Press CHANNEL 2 DISPLAY B/R pushbutton and set VERNIER ON/OFF switch to ON. Select dB/DIV resolution desired for transmission measurement and adjust CHANNEL 2 VERNIER control to place CRT trace on center graticule line.
16. Press 8750A CH 2 and INPUT pushbuttons to select CHANNEL 2 display. Normalize CRT display by pressing 8750A STORE INPUT then INPUT -MEM pushbuttons. Center graticule now represents 0 dB insertion loss.
17. Press 8755B CHANNEL 1 A/R DISPLAY pushbutton and connect device under test between 11666A TEST port and 11664A Detector.
18. The equipment is now calibrated for either a reflection (return loss) or transmission (insertion loss) measurement. Return loss is read directly by adding the 8755B CHANNEL 1 REFERENCE LEVEL setting to the CHANNEL 1 trace position below the center graticule line. Insertion loss is read directly by adding the 8755B CHANNEL 2 REFERENCE LEVEL setting to the CHANNEL 2 trace position below the center graticule line. If the trace is above the center graticule line, subtract that amount from the REFERENCE LEVEL setting.

Figure 3-10. Simultaneous Transmission, Reflection Measurement Using HP Model 8755B Swept Amplitude Analyzer (3 of 3)

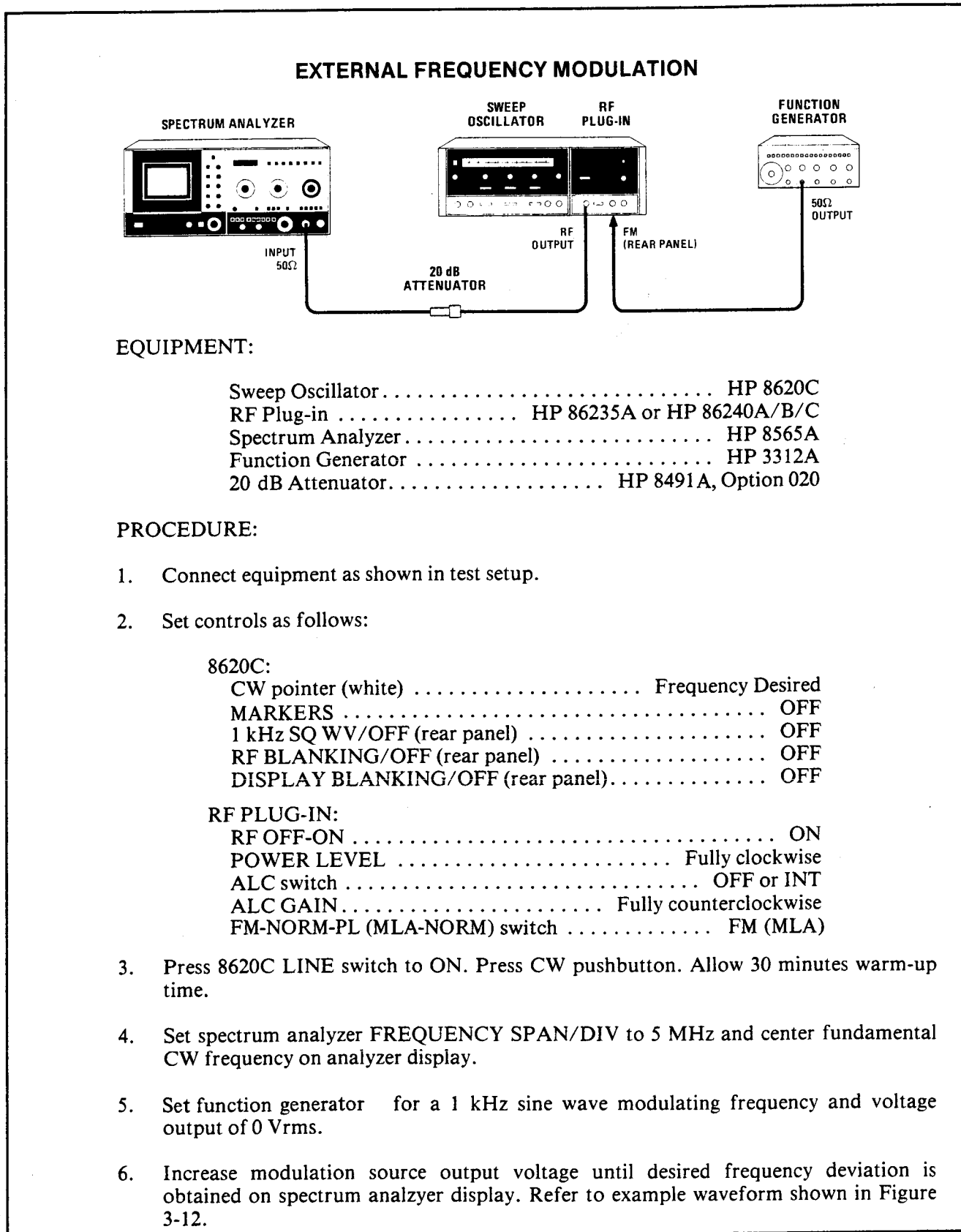

Figure 3-11. External FM Operation

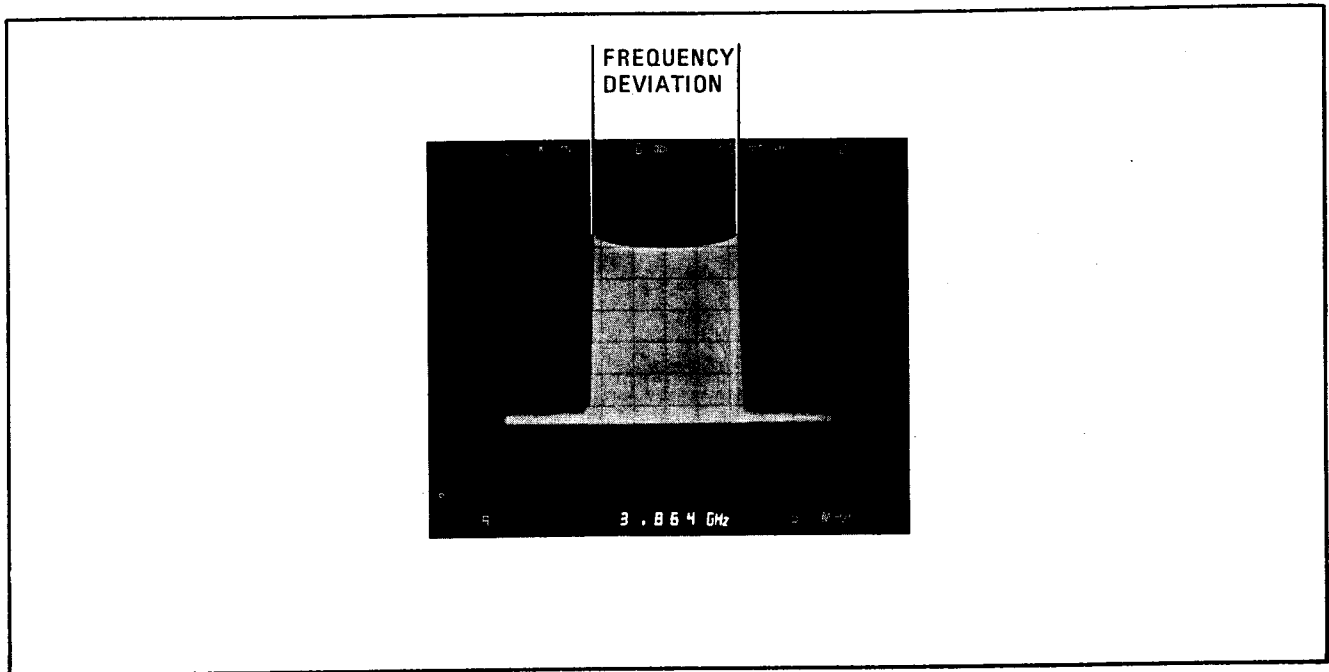

Figure 3-12. Spectrum Analyzer Display of Typical Frequency Modulated Waveform

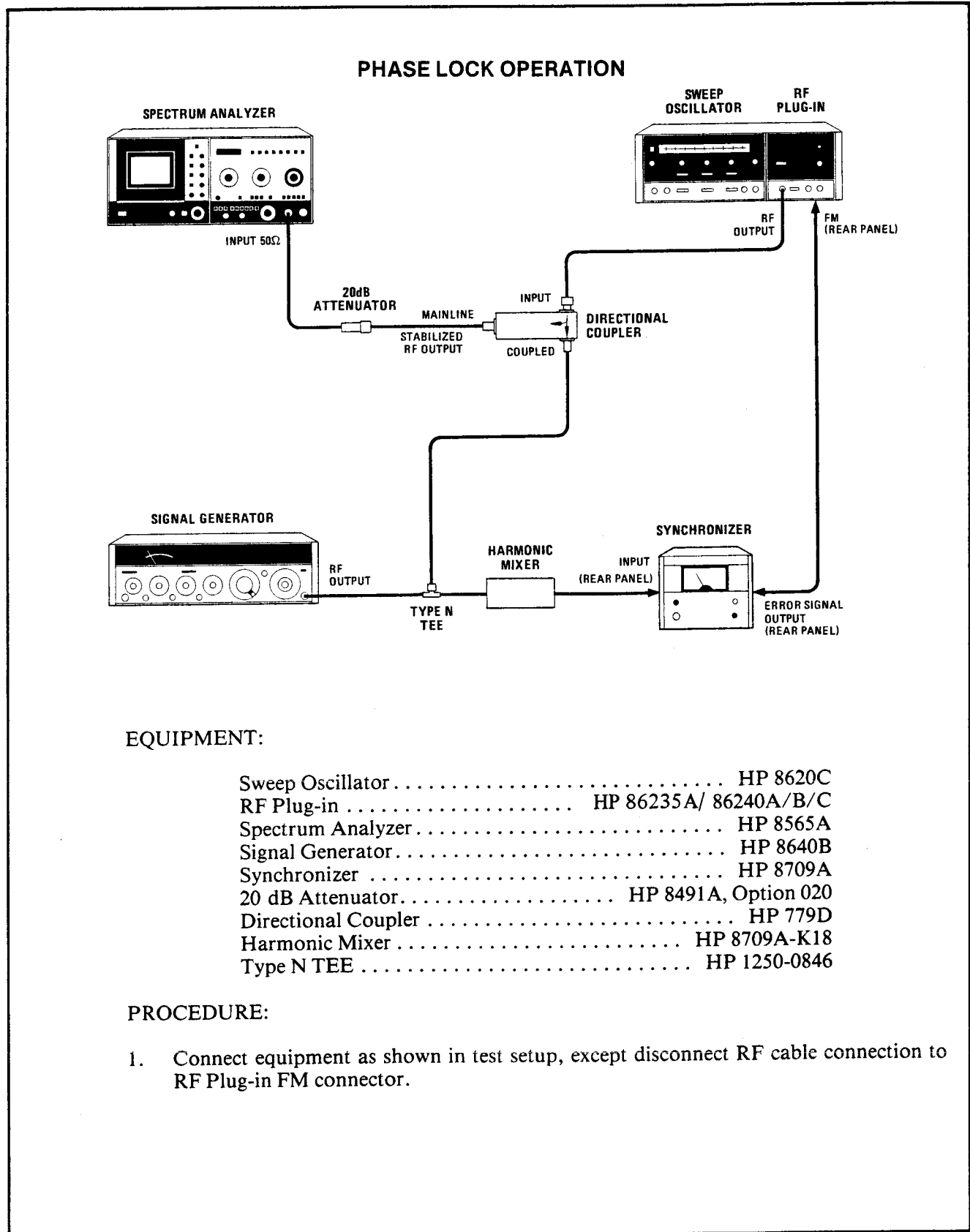

Figure 3-13. Phase Lock Operation

PHASE LOCK OPERATION

- Set controls as follows:

8620C:

CW MARKER pointer (white)..... Frequency Desired
 MARKERS OFF
 1 kHz SQ WV/OFF (rear panel) OFF
 RF BLANKING/OFF (rear panel) OFF
 DISPLAY BLANKING/OFF (rear panel)..... OFF

RF Plug-in:

RF OFF-ON ON
 POWER LEVEL Fully Clockwise
 ALC switch OFF INT
 ALC GAIN Fully Clockwise
 FM-NORM-PL (rear panel) PL

- Press 8620C LINE switch to ON. Press CW pushbutton. Allow 30 minutes warm-up time.
- Center fundamental CW frequency on spectrum analyzer display, unstabilized waveform should be similar to display in Figure 3-14.
- Set 8709A SYNCHRONIZER rear-panel MOD. SENS. switch to 6.00 MHz/VOLT position. (The 8709A rear-panel switch sets 8709A modulation sensitivity to match sensitivity of RF plug-in to be stabilized.)
- Connect 8709A ERROR OUT connector to RF Plug-in FM connector. Tune reference oscillator frequency until 8709A SYNCHRONIZER UNLOCKED light goes off.
- Retune sweep oscillator until 8709A PHASE ERROR Meter indication is centered. STABILIZED (phase-locked) waveform should be similar to display of Figure 3-15.

Figure 3-13. Phase Lock Operation (2 of 2)

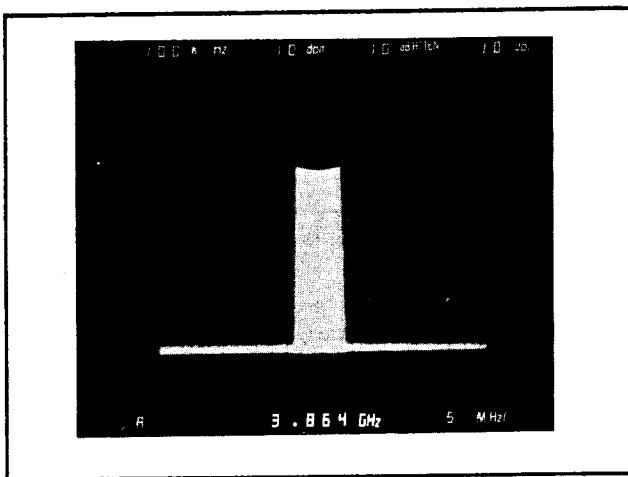

Figure 3-14. Spectrum Analyzer Display of Unstabilized CW Signal

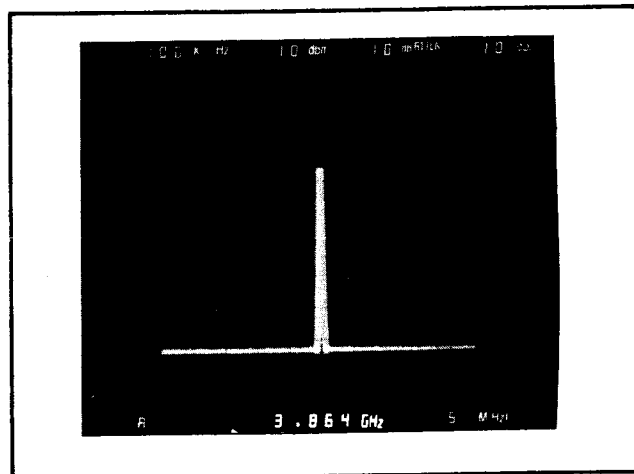
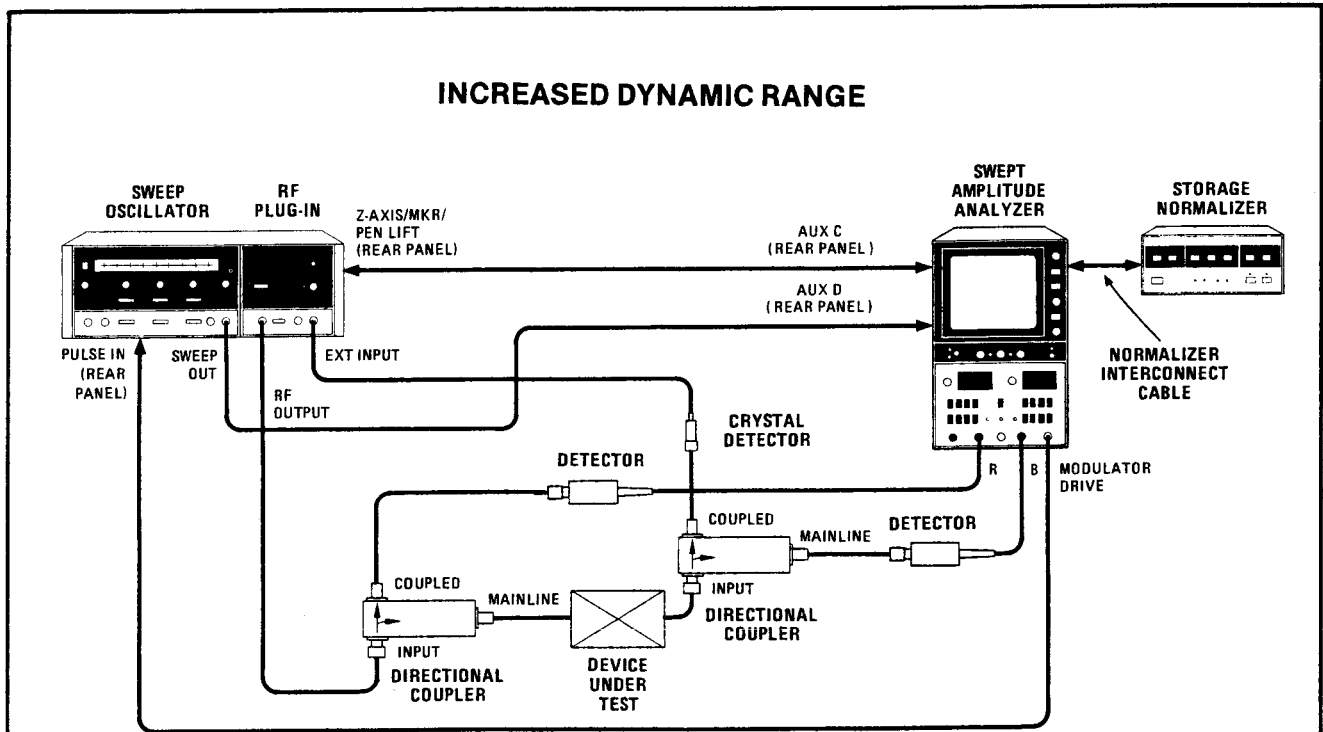

Figure 3-15. Spectrum Analyzer Display of Phase-Locked CW Signal



EQUIPMENT:

- Sweep Oscillator HP 8620C
- RF Plug-in HP 86235A or 86240A/B/C
- Swept Amplitude Analyzer HP 8755B/182T
- Directional Coupler (2 required)..... HP 779D
- Detector (2 required)..... HP 11664A
- Crystal Detector (Negative polarity)..... HP 423B
- Storage-Normalizer HP 8750A
- Normalizer Interconnect Cable HP 08750-60014

PROCEDURE:

1. Connect equipment as shown in test setup above with a direct connection between directional couplers (do not connect device under test).
2. Set controls as follows:

8620C:

- START MARKER pointer Low frequency end of scale
- STOP MARKER pointer High frequency end of scale
- MARKERS OFF
- 1 kHz SQ WV/OFF (rear panel) OFF
- RF BLANKING/OFF (rear panel) OFF
- DISPLAY BLANKING/OFF (rear panel) DISPLAY BLANKING

Figure 3-16. Increased Dynamic Range Using HP Model 8755B Swept Amplitude Analyzer (1 of 2)

INCREASED DYNAMIC RANGE

RF PLUG-IN:

RF OFF-ON ON
 ALC switch..... EXT
 ALC GAIN..... Fully counterclockwise
 POWER LEVEL..... Fully counterclockwise

3. Press 8620C LINE pushbutton switch ON. Allow 30 minutes warm-up time.
4. Press MARKER SWEEP pushbutton and set the START MARKER and STOP MARKER pointers to cover swept frequency required.

NOTE

The 8750A Storage-Normalizer and 8755B/182T Swept Amplitude Analyzer must be matched according to the procedure in Section III of the 8750A Operating and Service Manual.

5. Turn off 8755B CHANNEL 1 display by pressing one of the CHANNEL 1 DISPLAY pushbuttons part way in to "pop" out all of the CHANNEL 1 DISPLAY pushbuttons.
6. Press 8750A BYPASS pushbutton. Set 8755B CHANNEL 2 VERNIER ON/OFF switch to OFF, set CHANNEL 2 REFERENCE LEVEL thumbwheels to -00 dB, and select 10 dB/DIV resolution.
7. Press 8755B CHANNEL 2 DISPLAY REFERENCE POSITION pushbutton and adjust REFERENCE POSITION screwdriver adjustment to place CRT trace on center graticule line.
8. Press 8755B CHANNEL 2 DISPLAY B Pushbutton and adjust RF plug-in POWER LEVEL to place CRT trace one division above center graticule line (+ 10 dBm).
9. Press 8755B CHANNEL 2 DISPLAY B/R pushbutton and set VERNIER ON/OFF switch to ON. Adjust CHANNEL 1 VERNIER control to place CRT trace on center graticule line.
10. Press 8750A CH 2 and INPUT pushbuttons to select CHANNEL 2 display. Normalize CRT display by pressing 8750A STORE INPUT then INPUT -MEM pushbuttons. Center graticule line now represents 0 dB insertion loss.
11. Connect device under test between the two directional couplers as shown in the test setup.
12. Adjust CHANNEL 2 REFERENCE LEVEL thumbwheels to place CRT trace close to center graticule line. Insertion loss is read directly by adding the 8755B CHANNEL 2 REFERENCE LEVEL setting to the CRT trace position below the center graticule line. If the trace is above the center graticule line, subtract that amount from the REFERENCE LEVEL setting.

Figure 3-16. Increased Dynamic Range Using HP Model 8755B Swept Amplitude Analyzer (2 of 2)

SECTION IV PERFORMANCE TESTS

4-1. INTRODUCTION

4-2. The procedures in this section test the electrical performance of the instrument using the specifications of Table 1-1 as the performance standards. All tests can be performed without access to the interior of the instrument.

4-3. The performance test procedures must be performed in the sequence given, since most procedures rely on satisfactory test results in foregoing steps. If a test measurement is slightly out of tolerance, go to Section V and perform adjustment procedures. If a function fails to operate, go to Section VIII and perform troubleshooting.

NOTE

In the following procedure, an 8620C mainframe is specified. However, an 8620A or 8620B may be used; but the control names will be different from those called out in the procedures. These procedures assume that the mainframe is fully calibrated to its specifications.

NOTE

To ensure that RF Plug-in meets specifications listed in Table 1-1, Performance Tests should be performed at least every six months.

4-4. EQUIPMENT REQUIRED

4-5. Equipment required for the performance tests is listed in the Recommended Test Equipment Table in Section I. Any equipment that satisfies the critical specifications given in the table may be substituted for the recommended models.

4-6. ABBREVIATED PERFORMANCE VERIFICATION

4-7. The Operation Verification Tests of Section II are designed to test only the most critical specifications and operating features of the instrument. The Operation Verification Tests require much less time and equipment than the complete Performance Tests in this section and are recommended for verification of overall instrument operation after repair.

PERFORMANCE TESTS

4-8. FREQUENCY RANGE AND ACCURACY TEST

SPECIFICATION:

See Table 4-1 for frequency range and accuracy specifications.

NOTE

Allow 30 minutes warmup time.

PERFORMANCE TESTS

4-8. FREQUENCY RANGE AND ACCURACY TEST (Cont'd)

Table 4-1. Frequency Range and Accuracy Specifications

RF Plug-in	Frequency Range	Frequency Accuracy (at 25° C Ambient)
86235A	1.7 – 4.3 GHz	±20 MHz CW Mode* ±30 MHz All Sweep Modes**
86240A	2.0 – 8.4 GHz	±20 MHz All Sweep Modes* ±40 MHz All Sweep Modes**
86240B	2.0 – 8.4 GHz	±20 MHz CW Mode* ±50 MHz All Sweep Modes**
86240C	3.6 – 8.6 GHz	±20 MHz CW Mode* ±35 MHz All Sweep Modes**

*Approach desired CW frequency from low frequency end of band.
 **Sweep time >0.1 second

DESCRIPTION:

CW frequency is checked at three points across the band to determine if the RF signal is within frequency tolerance. FULL SWEEP is then selected and frequency at each endpoint is checked.

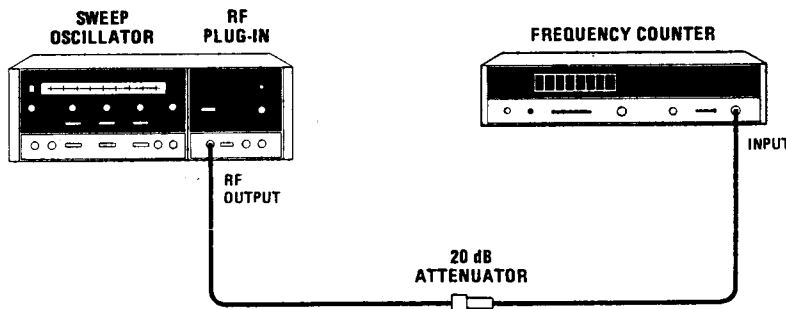

Figure 4-1. CW and Manual Sweep Accuracy Test Setup

NOTE

Equipment listed is for two test setups (Figures 4-1 and 4-2).

EQUIPMENT:

- Sweep Oscillator HP 8620C
- Frequency Counter HP 5340A
- Oscilloscope HP 180C/1801A/1820C
- Directional Coupler HP 779D
- Frequency Meter HP 536A
- Frequency Meter HP 537A
- Crystal Detector HP 423B
- 20-dB Attenuator HP 8491A, Option 020

PERFORMANCE TESTS

4-8. FREQUENCY RANGE AND ACCURACY TEST (Cont'd)

PROCEDURE:

- a. Connect equipment as shown in Figure 4-1.
- b. Set controls as follows:

8620C
 BAND Frequency of Plug-in installed
 CW MARKER pointer Center-scale
 MODE AUTO
 TRIGGER INT
 TIME-SECONDS 1 to .1
 1 kHz SQ WV/OFF (rear panel) OFF
 RF BLANKING/OFF (rear panel) RF BLANKING
 DISPLAY BLANKING/OFF (rear panel) OFF

RF PLUG-IN:
 RF OFF-ON ON
 ALC switch OFF or INT
 POWER LEVEL Fully clockwise
 FM-NORM-PL (MLA-NORM) switch NORM

- c. Press 8620C LINE pushbutton to ON; press CW pushbutton. Set frequency counter to measure frequency range of RF Plug-in. Allow 30 minutes warmup time.

NOTE

Always approach frequency settings from low-frequency end.

- d. Adjust CW MARKER pointer to high-frequency end, then to low-frequency end; repeat several times. Set CW pointer to low end of scale. Frequency counter indication should be within ± 20 MHz of low end of scale frequency listed in Table 4-2.
- e. Set 8620C CW MARKER pointer to center-scale. Frequency counter indication should be within ± 20 MHz of center scale frequency listed in Table 4-2.
- f. Set 8620C CW MARKER pointer to high-end of scale. Frequency counter indication should be within ± 20 MHz of high end of scale frequency listed in Table 4-2.

Table 4-2. Frequency Accuracy Test, CW Mode

RF Plug-in	Low-Frequency End of Scale	Center Scale Frequency	High-Frequency End of Scale
86235A	1.7 GHz	3.0 GHz	4.3 GHz
86240A/B	2.0 GHz	5.2 GHz	8.4 GHz
86240C	3.6 GHz	6.1 GHz	8.6 GHz

PERFORMANCE TESTS

4-8. FREQUENCY RANGE AND ACCURACY TEST (Cont'd)

Swept Frequency Endpoint Accuracy

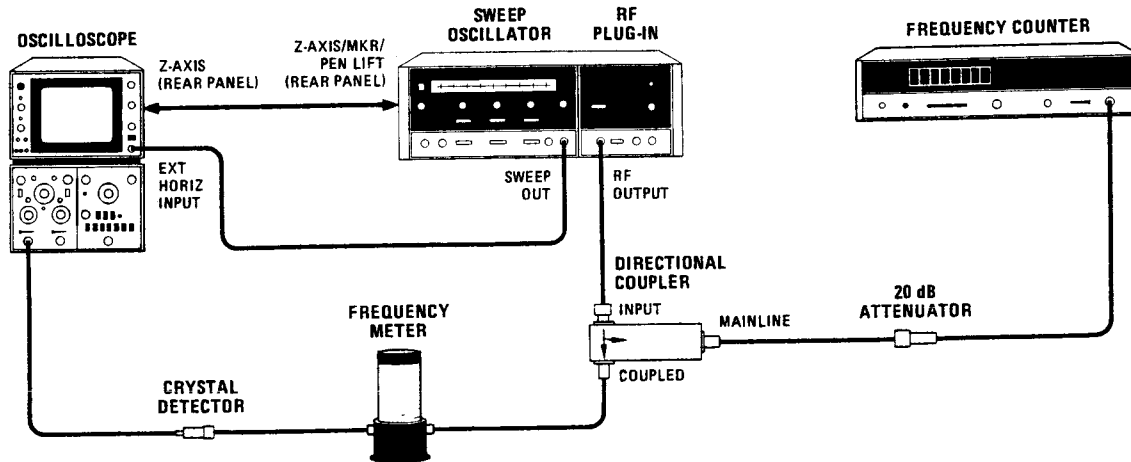

Figure 4-2. Swept Frequency Endpoint and Marker Accuracy Test Setup

- g. Connect equipment as shown in Figure 4-2. (Use HP 536A Frequency Meter for frequencies less than 4 GHz and HP 537A Frequency Meter for frequencies greater than 4 GHz.)
- h. Press 8620C CW pushbutton. Adjust CW MARKER control for frequency counter indication same as low end of scale frequency listed in Table 4-2.
- i. Adjust frequency meter for maximum change in amplitude on oscilloscope. Note dial setting of frequency meter.
- j. Press 8620C FULL SWEEP pushbutton, and set MODE switch to AUTO.
- k. Adjust frequency meter to low-frequency endpoint on oscilloscope. Determine the difference between end frequency and sweeper dial setting by subtracting this frequency meter setting from frequency meter setting noted in step i. This frequency difference must be less than 30 MHz for 86235A, less than 40 MHz for 86240A, less than 50 MHz for 86240B, or less than 35 MHz for 86240C.
- l. Repeat steps g through k for center and high-frequency end of scale.

4-9. FREQUENCY STABILITY TEST

SPECIFICATIONS:

See Table 4-3 for frequency stability specifications.

PERFORMANCE TESTS

4.9. FREQUENCY STABILITY TEST (Cont'd)

Table 4-3. Frequency Stability Specifications

10% Line Voltage Change	10 dB Power Level Change	3:1 Load SWR	Temperature
±40 kHz	±1 MHz	±250 kHz	±500 kHz/°C

DESCRIPTION:

Frequency is measured for changes in line voltage, power level, source match, or temperature.

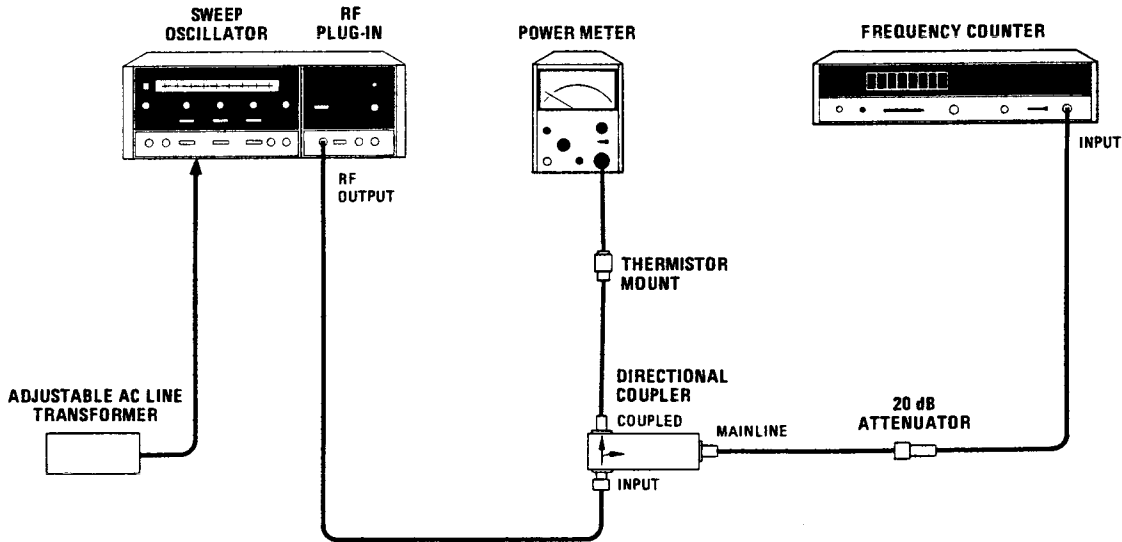

Figure 4-3. Frequency Stability Test Setup

NOTE

Equipment listed is for two test setups (Figures 4-3 and 4-4).

EQUIPMENT:

- Sweep Oscillator HP 8620C
- Spectrum Analyzer HP 8565A
- Frequency Counter HP 5340A
- Power Meter HP 432A
- Thermistor Mount HP 8478B
- Adjustable AC Line Transformer General Radio MT3A
- Directional Coupler HP 779D
- 20 dB Attenuator HP 8491A, Option 020
- 3 dB Attenuator HP 8491A, Option 003
- Adjustable Short Microlab/FXR SO-6MN

PERFORMANCE TESTS

4-9. FREQUENCY STABILITY TEST (Cont'd)

PROCEDURE:

- a. Connect equipment as shown in Figure 4-3.
- b. Set controls as follows:

8620C:

BAND Frequency of Plug-in installed
 CW MARKER pointer Center-scale
 1 kHz SQ WV/OFF (rear panel) OFF
 RF BLANKING/OFF (rear panel) RF BLANKING
 DISPLAY BLANKING/OFF (rear panel) OFF

RF PLUG-IN:

RF OFF-ON ON
 ALC switch OFF or INT
 FM-NORM-PL (MLA-NORM) switch NORM

- c. Adjust RF Plug-in for specified maximum power.
- d. Set adjustable line voltage transformer to 115 Vac. Press 8620C LINE pushbutton to ON. Press CW pushbutton. Allow 30 minutes warmup time.

Frequency Change with Line Voltage Change:

- e. Record frequency counter indication at 115 Vac.
- f. Set line voltage to 103 Vac with adjustable line transformer. Frequency change from that noted in step e should be less than 40 kHz.
- g. Set line voltage to 127 Vac with adjustable line transformer. Frequency change from that noted in step e should be less than 40 kHz. Return line voltage to 115 Vac.
- h. Note frequency counter indication. Using RF Plug-in POWER LEVEL control, decrease power by 10 dB as indicated on power meter. Frequency change should be less than 1.0 MHz. Readjust RF Plug-in for specified maximum power.

Frequency Change with 3:1 Load SWR:

- i. Connect equipment as shown in Figure 4-4. Allow 30 minutes warmup time.
- j. Center output signal on spectrum analyzer display.
- k. Set spectrum analyzer RESOLUTION BW to 10 kHz and FREQUENCY SPAN/DIV to 50 kHz while keeping signal centered on display.

PERFORMANCE TESTS

4-9. FREQUENCY STABILITY TEST (Cont'd)

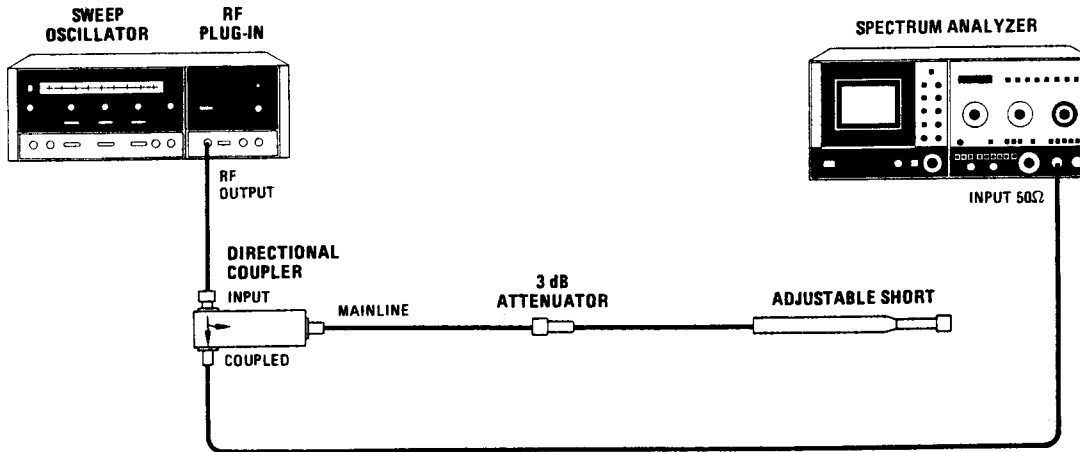

Figure 4-4. 3:1 Load SWR Test Setup

- l. Set spectrum analyzer AMPLITUDE SCALE, LOG/DIV to 10 dB and adjust for full vertical display.
- m. Set sweep time to 20 msec/division, internal sweep source, and free run sweep trigger.
- n. Tune adjustable short through full range while observing frequency change on analyzer. Frequency change must be less than ± 250 kHz.
- o. Repeat steps j through n for low end and high end of frequency band.

Frequency Change with Temperature Change:

NOTE

Verification of the frequency stability specification for temperature changes requires the RF Plug-in to be placed in a controlled environment (i.e., heat chamber).

- p. Connect frequency counter (through 20-dB attenuator) to RF OUTPUT of RF Plug-in. Allow 30 minutes warmup time.
- q. Adjust RF Plug-in for specified maximum power. Note frequency counter indication.
- r. Change ambient temperature 10°C within the range of 0°C to 55°C . Allow 30 minutes settling time.
- s. Note frequency counter indication. Frequency change from that noted in step q should be within ± 5 MHz.

PERFORMANCE TESTS

4-10. RESIDUAL FM IN 10 kHz BANDWIDTH TEST

SPECIFICATION:

Residual FM in 10 kHz Bandwidth (CW Mode):

86235A: <7 kHz peak

86240A/B/C: <9 kHz peak

DESCRIPTION:

RF output signal is displayed on a spectrum analyzer. Residual FM is observed on a storage display by displaying five superimposed traces.

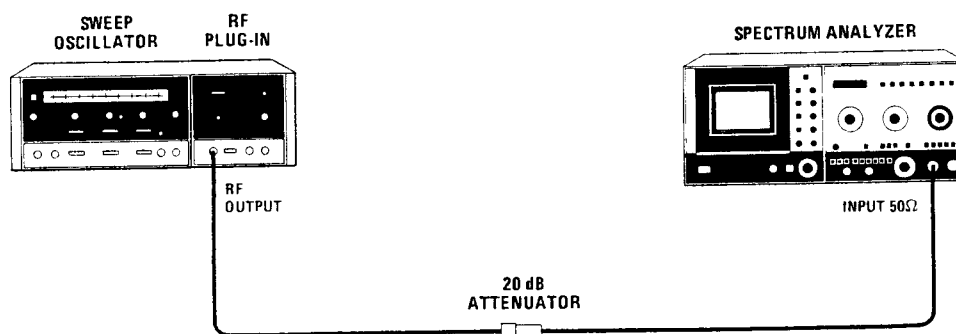

Figure 4-5. Residual FM Test Setup

EQUIPMENT:

Sweep Oscillator.....	HP 8620C
Spectrum Analyzer.....	HP 8565A
20 dB Attenuator	HP 8491A, Option 020

PROCEDURE:

- a. Connect equipment as shown in Figure 4-5.
- b. Set controls as follows:

8620C:
 BAND..... Frequency of Plug-in installed
 CW MARKER pointer Center-scale
 1 kHz SQ WV/OFF (rear panel) OFF
 RF BLANKING/OFF (rear panel) OFF
 DISPLAY BLANKING/OFF (rear panel) OFF

RF PLUG-IN:
 RF OFF-ON..... ON
 ALC switch OFF or INT
 POWER LEVEL Fully clockwise
 FM-NORM-PL (MLA-NORM) switch NORM

PERFORMANCE TESTS

4-10. RESIDUAL FM IN 10 kHz BANDWIDTH TEST (Cont'd)

- c. Press 8620C LINE pushbutton to ON. Press CW pushbutton. Allow 30 minutes warmup time.
- d. Center RF output signal on spectrum analyzer.
- e. Set spectrum analyzer RESOLUTION BW to 10 kHz and FREQUENCY SPAN/DIV to 5 kHz while keeping signal centered on CRT display. Set TUNING STABILIZER to ON.
- f. On spectrum analyzer, select LINEAR display and adjust REFERENCE LEVEL controls for a full eight division display.
- g. Set SWEEP TIME/DIV to 20 mSEC and set SWEEP TRIGGER to SINGLE sweep. Set PERSIST control fully clockwise and ERASE the trace.
- h. Push START/RESET pushbutton five times at approximately one second intervals and store resultant traces on CRT screen. Display should be similar to that shown in Figure 4-6.

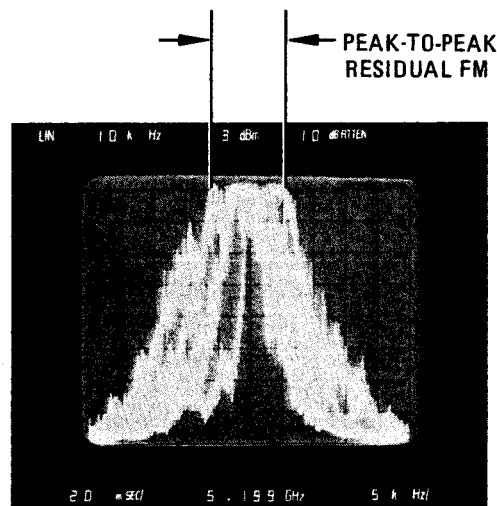

Figure 4-6. Residual FM Displayed on Spectrum Analyzer

- i. FM deviation measured across top of trace should be < 14 kHz (2.8 divisions) for 86235A or < 18 kHz (3.6 divisions) for 86240A/B/C.
-

PERFORMANCE TESTS

4-11. POWER LEVEL AND VARIATION TEST

SPECIFICATIONS:

See Table 4-4 for power level and variation specifications.

Table 4-4. Power Level and Variation specifications

RF Plug-in	Maximum Leveled Power (25°C) ⁴	Internally Leveled ¹ (Option 001 or 86240B)	Externally Leveled ¹ Crystal ² or Power Meter ³	Power Calibration Accuracy
86235A	>+16 dBm (40 mW)	<±0.8 dB	<±0.1 dB	±2 dB
86240A	>+16 dBm (40 mW)	<±1.0 dB	<±0.1 dB	±2 dB
86240B	>+13 dBm (20 mW)	<±0.5 dB	<±0.1 dB	±1 dB
86240C	>+16 dBm (40 mW)	<±0.8 dB	<±0.1 dB	±2 dB

¹ Variation of ±1.0 dB means 2.0 dB peak-to-peak total variation.
² Specification excludes variations due to crystal detector and directional coupler.
³ Specification excludes variations due to thermistor mount and directional coupler.
⁴ For Option 002, less 1 dB (power loss due to insertion loss of attenuator).

DESCRIPTION:

Maximum leveled power is checked with internal leveling, crystal detector leveling, and power meter leveling. In each mode, the power variations are measured on the oscilloscope trace. The trace is calibrated by changing the RF output power by the amount of the specification as noted on the power meter and the corresponding change in trace on the oscilloscope. In external leveling modes, the leveling variations are monitored in the feedback loop; therefore, no error exists in the measurement. However, the usable RF output power from the directional coupler does contain variations in power level that are due to the frequency response of the directional coupler and the crystal detector or the thermistor mount. The accuracy of the POWER LEVEL potentiometer calibration is also measured.

PERFORMANCE TESTS

4-11. POWER LEVEL AND VARIATION TEST (Cont'd)

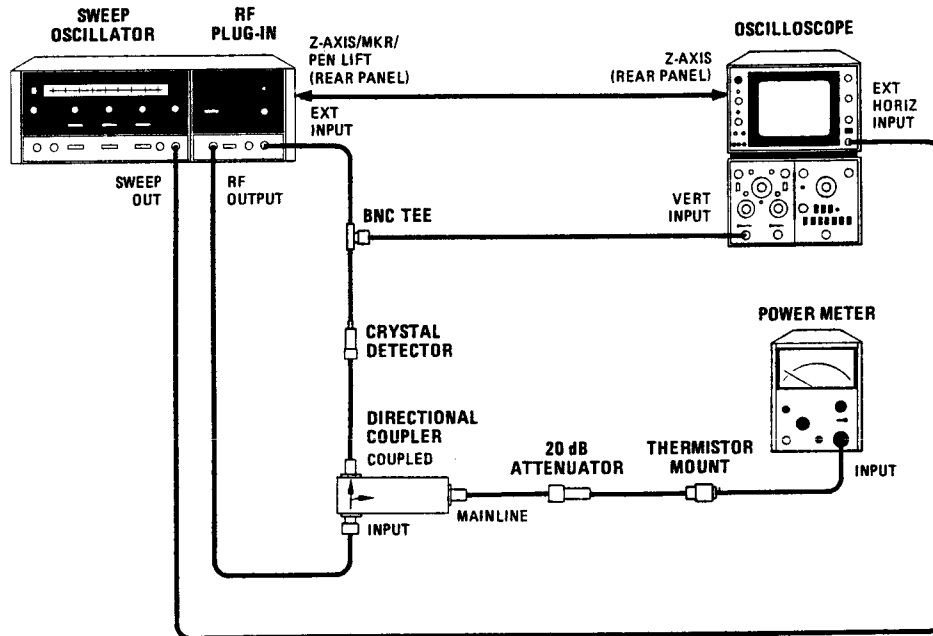

Figure 4-7. Crystal Detector Leveling Test Setup

NOTE

Equipment listed is for three test setups (Figures 4-7, 4-8 and 4-9).

EQUIPMENT:

Sweep Oscillator	HP 8620C
Power Meter	HP 432A
Thermistor Mount	HP 8478B
Oscilloscope	HP 180C/1801A/1820C
Crystal Detector	HP 423B
Directional Coupler	HP 779D
20 dB Attenuator	HP 8491A, Option 020

PROCEDURE:

External leveling with crystal detector:

- a. Connect equipment as shown in Figure 4-7.

PERFORMANCE TESTS

4-11. POWER LEVEL AND VARIATION TEST (Cont'd)

b. Set controls as follows:

8620C

BAND	Frequency of Plug-in installed
CW MARKER pointer	Center-scale
ΔF Control	Fully counterclockwise
MODE	AUTO
TRIGGER	INT
TIME-SECONDS1 to .01
1 kHz SQ WV/OFF (rear panel)	OFF
RF BLANKING/OFF (rear panel)	OFF
DISPLAY BLANKING/OFF (rear panel)	DISPLAY BLANKING

RF PLUG-IN

RF OFF-ON	ON
ALC switch	EXT
POWER LEVEL	Fully clockwise
ALC GAIN	Fully clockwise

- c. Press 8620C LINE pushbutton to ON; FULL SWEEP pushbutton should light. Allow 30 minutes warmup time.
- d. Adjust RF Plug-in ALC GAIN and POWER LEVEL controls to obtain highest power meter indication with UNLEVELED light not lit. (If oscillations appear on trace, adjust ALC GAIN and POWER LEVEL controls counterclockwise as necessary to get a leveled trace. Power meter indication plus loss of 20 dB attenuator should be:
- > +16 dBm for 86235A and 86240A/C (1 dB less for Option 002)
 - > +13 dBm for 86240B (1 dB less for Option 002)
- e. Press mainframe ΔF pushbutton. Adjust oscilloscope trace to bottom of display and note trace position. Decrease output power indication at power meter by 0.2 dB using RF Plug-in POWER LEVEL control. Note position of oscilloscope trace. (Area between two positions noted represents leveling tolerance of ± 0.1 dB.)
- f. Press mainframe FULL SWEEP pushbutton. Adjust RF Plug-in POWER LEVEL control fully clockwise, then counterclockwise until UNLEVELED lamp goes out at maximum leveled power.
- g. Adjust position of oscilloscope trace vertically so it is displayed between upper and lower specification limits noted in step e. Highest and lowest portion of sweep trace must be within 0.2 dB peak-to-peak limit noted.

External Leveling with Power Meter:

h. Connect equipment as shown in Figure 4-8.

PERFORMANCE TESTS

4-11. POWER LEVEL AND VARIATION TEST (Cont'd)

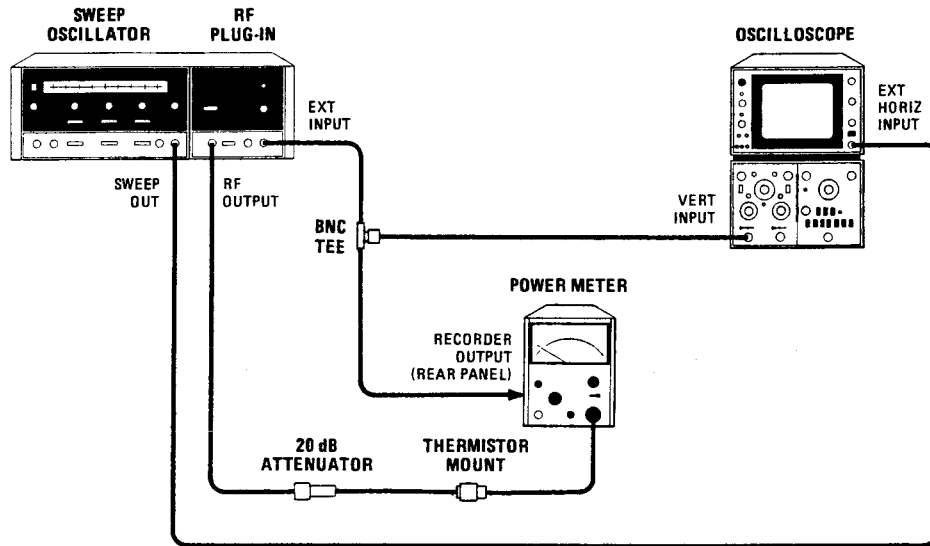

Figure 4-8. Power Meter Leveling Test Setup

i. Set controls as follows:

8620C:

- BAND..... Frequency of Plug-in installed
- CW MARKER pointer Center-scale
- MODE AUTO
- TRIGGER..... INT
- TIME-SECONDS 100 — 10
- 1 kHz SQ WV/OFF (rear panel) OFF
- RF BLANKING/OFF (rear panel) OFF
- DISPLAY BLANKING/OFF (rear panel) OFF

RF PLUG-IN:

- RF OFF-ON ON
- ALC switch MTR
- POWER LEVEL Fully clockwise

NOTE

For power meter leveling, sweep rates slower than 10 seconds per sweep should be used. The rate of leveling is dependent on the comparatively slow response of the thermistor mount to power level changes.

PERFORMANCE TESTS

4-11. POWER LEVEL AND VARIATION TEST (Cont'd)

- j. Press mainframe FULL SWEEP pushbutton. Set power meter range to obtain meter indication in upper half of scale. Adjust RF Plug-in POWER LEVEL and ALC GAIN controls to obtain flat RF power level across the band as indicated on oscilloscope. (If loop oscillations occur on oscilloscope trace turn ALC GAIN control in counterclockwise direction.
- k. Adjust RF Plug-in POWER LEVEL control fully clockwise, then counterclockwise until UNLEVELED light goes out.
- l. Set mainframe MODE switch to MANUAL. Adjust MANUAL sweep control slowly through full range and note maximum and minimum power meter indications. Difference between maximum and minimum power meter indications should be <math>< 0.2 \text{ dB}</math>.

Internal Leveling (Option 001 or standard 86240B):

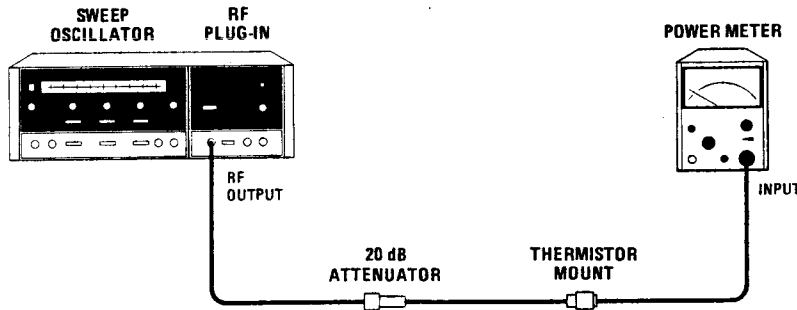

Figure 4-9. Internal Leveling Test Setup

- m. Connect equipment as shown in Figure 4-9.
- n. Set controls as follows:

8620C:	
BAND	Position for Plug-in installed
CW MARKER pointer	Center-scale
MARKERS	OFF
MODE	MANUAL
TRIGGER	INT
TIME-SECONDS1 — .01
1 kHz SQ WV/OFF (rear panel)	OFF
RF BLANKING/OFF (rear panel)	OFF
DISPLAY BLANKING/OFF (rear panel)	OFF
LINE	ON
RF PLUG-IN:	
RF OFF-ON	ON
ALC switch	INT

PERFORMANCE TESTS

4-11. POWER LEVEL AND VARIATION TEST (Cont'd)

- o. Adjust RF Plug-in POWER LEVEL and ALC controls for maximum leveled power. Adjust MANUAL sweep control slowly through full range and note maximum and minimum power meter indications. Difference between maximum and minimum power should be:
 - 86235A: <1.6 dB
 - 86240A: <2.0 dB
 - 86240B: <1.0 dB
 - 86240C: <1.6 dB

Power Calibration Accuracy (Option 001 or standard 86240B)

- p. Connect equipment as shown in Figure 4-9, but substitute a 10 dB attenuator for the 20 dB attenuator.
- q. Press CW pushbutton.
- r. Measure power at each indicated integer over the range of the POWER LEVEL control on the RF Plug-in. Accuracy of the POWER LEVEL control calibration should be ± 2 dB for 86235A, 86240A/C and ± 1 dB for 86240B.

4-12. POWER LEVEL ATTENUATOR ACCURACY TEST (Option 002)

SPECIFICATION:

- 86235A: ± 0.16 dB per 10 dB step
- 86240A/B/C: ± 0.3 dB per 10 dB Step

DESCRIPTION:

Attenuation accuracy of the 0 to 70-dB Step Attenuator is measured to ensure that the difference between each attenuator setting and a reference level meets the specification.

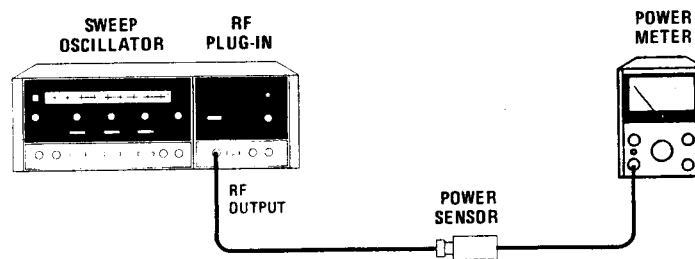

Figure 4-10. Power Level Attenuator Accuracy Test Setup

EQUIPMENT:

Sweep Oscillator.....	HP 8620C
Power Meter.....	HP 435A
Power Sensor.....	HP 8481A

PERFORMANCE TESTS

4-12. POWER LEVEL ATTENUATOR ACCURACY TEST (Option 002) (Cont'd)

PROCEDURE:

- a. Press 8620C LINE Pushbutton ON and press CW pushbutton. Allow 30 minutes warmup time.
- b. Set controls as follows:

8620C:

BAND Frequency of Plug-in installed
 CW MARKER pointer Center-scale
 1 kHz SQ WV/OFF (rear panel) OFF
 RF BLANKING/OFF (rear panel) OFF
 DISPLAY BLANKING/OFF (rear panel) OFF

RF PLUG-IN:

RF OFF-ON OFF
 ALC switch OFF or INT
 POWER LEVEL Fully clockwise
 FM-NORM-PL (MLA-NORM) switch NORM
 POWER LEVEL attenuator 0

- c. Set power meter range switch to +20 dBm and connect power sensor to RF OUTPUT as shown in Figure 4-10. ZERO power meter and set RF Plug-in RF OFF-ON switch to ON.
- d. Change power meter range, if necessary, and adjust RF Plug-in POWER LEVEL control for convenient reference on upper half of power meter scale.
- e. Set RF Plug-in POWER LEVEL attenuator to -10 position and change power meter downrange (counterclockwise) by 10 dBm. Power meter should indicate reference level set in step d ± 0.16 dB for 86235A or ± 0.3 dB for 86240A/B/C. Record deviation from reference set in step d.

_____ dB Deviation
- f. Set RF Plug-in POWER LEVEL attenuator to -20 position and change power meter downrange (counterclockwise) by 10 dBm. Power meter should indicate reference level set in step d ± 0.32 dB for 86235A or ± 0.6 dB for 86240A/B/C. Record deviation from reference set in step d.

_____ dB Deviation
- g. Set RF Plug-in POWER LEVEL attenuator to -30 position and change power meter downrange (counterclockwise) by 10 dBm. Power meter should indicate reference level set in step d ± 0.48 dB for 86235A or ± 0.9 dB for 86240A/B/C.

PERFORMANCE TESTS

4-12. POWER LEVEL ATTENUATOR ACCURACY TEST (Option 002) (Cont'd)

h. Set RF Plug-in POWER LEVEL attenuator to -40 position and change power meter downrange (counterclockwise) by 10 dBm. Set RF Plug-in RF OFF-ON switch to OFF and ZERO power meter. Return RF OFF-ON switch to ON. Power meter should indicate reference level set in step d ± 0.64 dB for 86235A or ± 1.2 dB for 86240A/B/C. Record deviation from reference set in step d.

_____ dB Deviation

- i. Add deviation recorded in step e to deviation recorded in step h. Result should be less than 0.80 dB for 86235A or ± 1.5 dB for 86240A/B/C.
- j. Add deviation recorded in step f to deviation recorded in step h. Result should be less than ± 0.96 dB for 86235A or ± 1.8 dB for 86240A/B/C.
- k. Add deviations from steps e, f, and h. Result should be less than ± 1.12 dB for 86235A or ± 2.1 dB for 86240A/B/C.

4-13. HARMONIC SPURIOUS SIGNALS TEST

SPECIFICATION:

Harmonic spurious signals (down from fundamental at specified leveled power): See Table 4-5.

Table 4-5. Harmonic Spurious Signals Specifications

RF Plug-in	Harmonics	
	At 40 mW	At 20 mW
86235A 86240A/C 86240B	>20 dB down >16 dB down	>20 dB down >45 dB down

PERFORMANCE TESTS

4-13. HARMONIC SPURIOUS SIGNALS TEST (Cont'd)

DESCRIPTION:

Harmonics generated by the RF Plug-in are observed by the use of a Swept Amplitude Analyzer and band-pass filters.

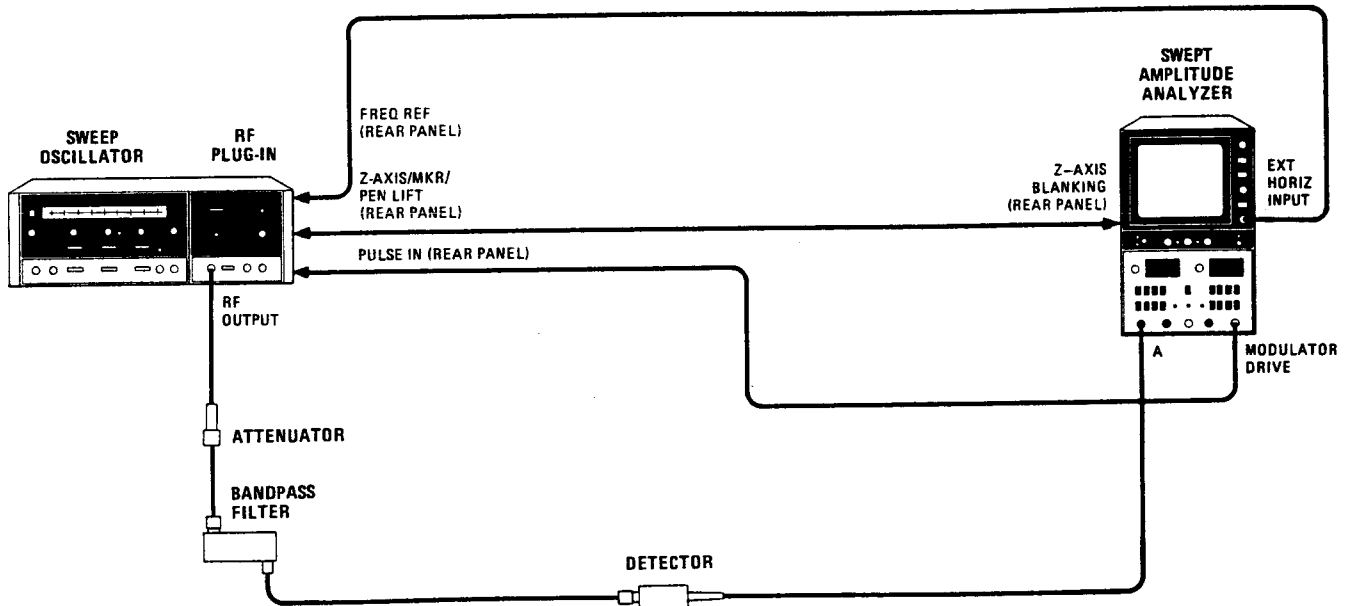

Figure 4-11. Harmonic Spurious Signals Test Setup

EQUIPMENT:

Sweep Oscillator.....	HP 8620C
Swept Amplitude Analyzer.....	HP 8755B/182T
Attenuator	
20 d for 86235A/86240A/C.....	HP 8491A, Option 020
6 dB for 86240B.....	HP 8491A, Option 006
4 to 8 GHz Bandpass Filter.....	HP 8435A
6 to 8 GHz Bandpass Filter.....	HP 8433A
8 to 12 GHz Bandpass Filter.....	HP 8436A
Detector.....	HP 11664A

PROCEDURE:

- a. Connect equipment as shown in Figure 4-11. Press 8620C LINE pushbutton to ON. Allow 30 minutes warmup time.

PERFORMANCE TESTS

4-13. HARMONIC SPURIOUS SIGNALS TEST (Cont'd)

b. Set controls as follows:

8620C:

MODE AUTO
 TRIGGER..... INT
 TIME-SECONDS 1 — .1
 TIME-SECONDS VERNIER..... Fully clockwise
 MARKERS..... OFF
 RF BLANKING/OFF (rear panel) RF BLANKING
 DISPLAY BLANKING/OFF
 (rear panel) DISPLAY BLANKING
 1 kHz SQ WV/OFF OFF

RF Plug-in:

RF OFF-ON ON
 POWER LEVEL + 13 dBm
 ALC Switch INT or EXT
 SLOPE CAL (Fully counterclockwise)

- c. Connect the 4 — 8 GHz bandpass filter between the attenuator and the detector.
- d. Set the 8755B offset VERNIER to bring the top of the trace on the display one division below the top of the screen (see Figure 4-12). If necessary, adjust SLOPE for flat trace.
- e. Any harmonics displayed should be greater than 20 dB down from the fundamental for the 86235A and 86240A/C or greater than 45 dB down for the 86240B.
- f. Increase POWER LEVEL to + 16 dBm for all instruments except 86240B.
- g. Repeat step d.
- h. Any harmonics displayed should be greater than 20 dB down from the fundamental for the 86235A or greater than 16 dB down for the 86240A/C. (This specification does not apply to the 86240B.)
- i. Remove 4 — 8 GHz bandpass filter, install 6 — 8 GHz bandpass filter, and repeat steps d through h.
- j. Remove 6 — 8 GHz bandpass filter, install 8 — 12 GHz bandpass filter, and repeat steps d through h.

PERFORMANCE TESTS

4-13. HARMONIC SPURIOUS SIGNALS TEST (Cont'd)

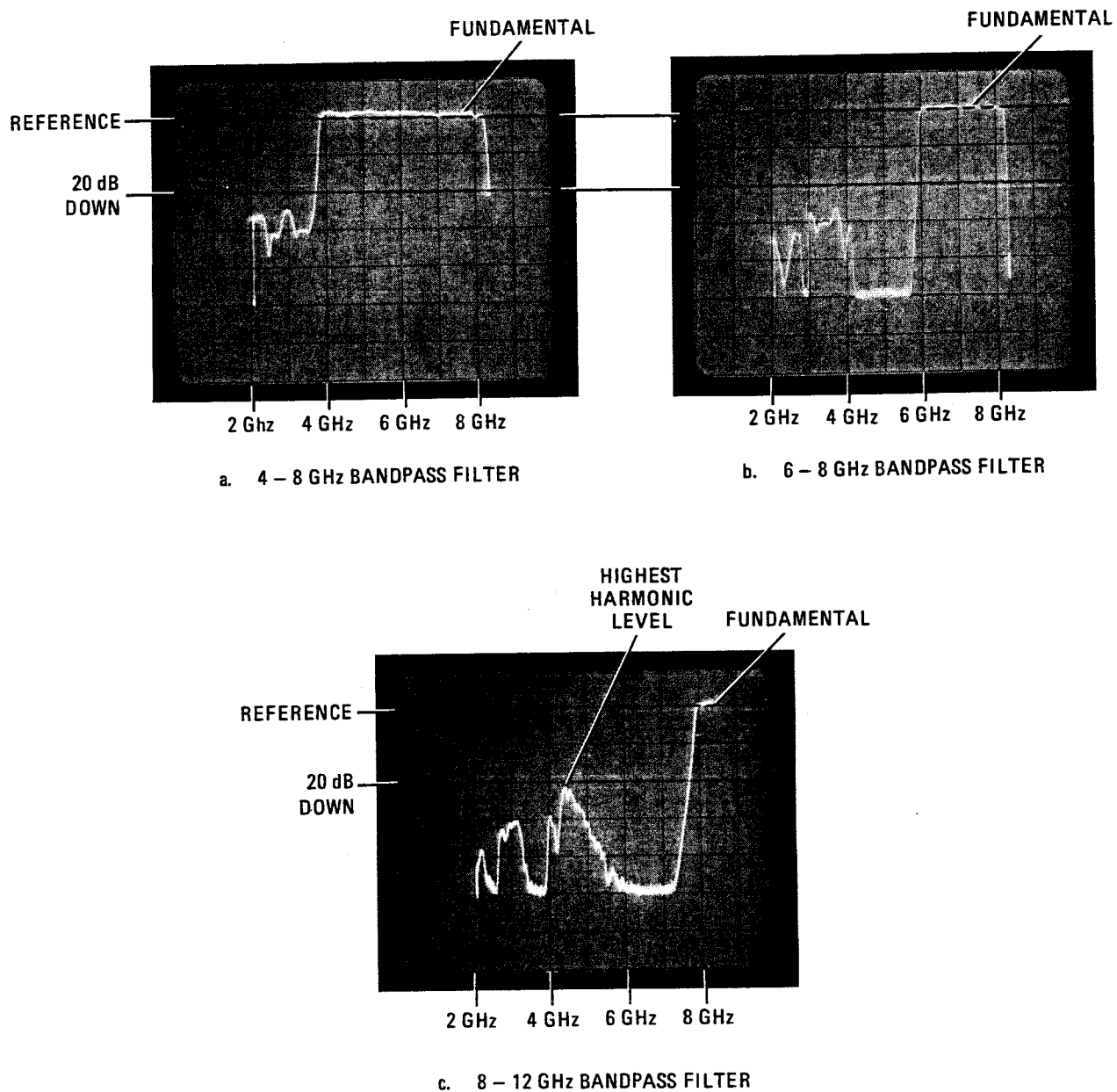

Figure 4-12. Harmonics with Bandpass Filters

PERFORMANCE TESTS

4-14. NONHARMONIC SPURIOUS SIGNALS TEST

SPECIFICATION:

Spurious signals (down from fundamental at specified maximum power): >60 dB.

DESCRIPTION:

RF output signal from sweep oscillator is displayed on a spectrum analyzer to verify that spurious signals are down from fundamental signal by specified amount.

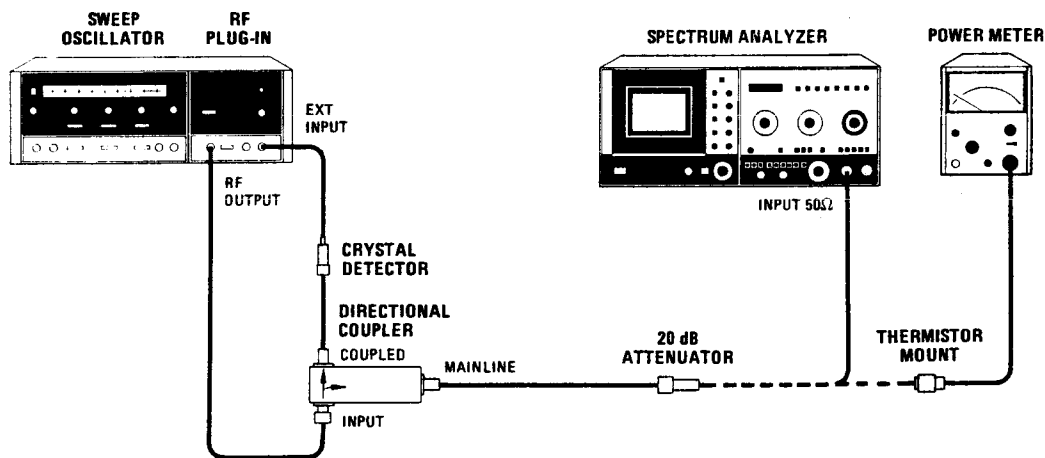

Figure 4-13. Nonharmonic Spurious Signals Test Setup

EQUIPMENT:

Sweep Oscillator.....	HP 8620C
Spectrum Analyzer.....	HP 8565A
Power Meter.....	HP 432A
Thermistor Mount.....	HP 8478B
20 dB Attenuator.....	HP 8491A, Option 020
Directional Coupler.....	HP 779D
Crystal Detector.....	HP 423B

PROCEDURE:

- a. Connect equipment as shown in Figure 4-13 with power meter connected to 20 dB Attenuator. Press 8620C LINE Pushbutton to ON. Allow 30 minutes warmup time.
- b. Set controls as follows:

8620C:

BAND.....	Frequency of Plug-in installed
CW MARKER pointer.....	Center scale
DISPLAY BLANKING/OFF (rear panel).....	OFF
RF BLANKING/OFF (rear panel).....	RF BLANKING
1 kHz SQ WV/OFF (rear panel).....	OFF

PERFORMANCE TESTS

4-14. NONHARMONIC SPURIOUS SIGNALS TEST (Cont'd)

- RF Plug-in:
 - RF OFF-ON ON
 - ALC switch..... EXT
- 8565A:
 - FREQUENCY BAND GHz As required for Plug-in frequency
 - INPUT ATTEN 10 dB
 - FREQUENCY SPAN/DIV 1 MHz
 - RESOLUTION BW 10 kHz
 - SWEEP TIME/DIV AUTO

- c. Press CW pushbutton on 8620C.
- d. Adjust RF Plug-in POWER LEVEL and ALC GAIN control for specified maximum leveled power.
- e. Disconnect power meter. Connect spectrum analyzer as shown in Figure 4-10.

NOTE

The spectrum analyzer originates some mixing harmonics that may appear on the display. If a signal is in question, increase the spectrum analyzer input attenuation by 10 dBm, note if signal decreases in amplitude by 10 dB, then return the attenuator to the original position. If the signal in question comes from an external source, it will change by 10 dB. If the signal in question originates in the spectrum analyzer, the level will either change by greater or less than 10 dB or may not change at all.

- f. Adjust REF LEVEL controls of spectrum analyzer to place fundamental signal at top graticule line. Set FREQUENCY SPAN/DIV to F (full band) and set SWEEP TIME/DIV to 1SEC.
- g. Adjust 8620C CW MARKER control through the frequency band and observe spurious signals.
- h. Measure difference in dB between spurious signal level and level of fundamental signal. Difference should be >60 dB (greater than six divisions down).

4-15. RESIDUAL AM TEST

SPECIFICATION:

Residual AM: (AM noise in 100 kHz bandwidth below maximum specified power level): > 50 dB down.

PERFORMANCE TESTS

4-15. RESIDUAL AM TEST (Cont'd)

DESCRIPTION:

RF output signal from RF Plug-in is amplitude modulated with square wave from 8620C. This modulated signal is used to establish a reference on HP Model 3400A RMS Voltmeter that is 9 dB below actual carrier signal. The 9 dB reduction occurs because of voltmeter response to square wave and square-law response of crystal detector. Modulation is then removed and magnitude of residual AM component is measured with respect to established reference.

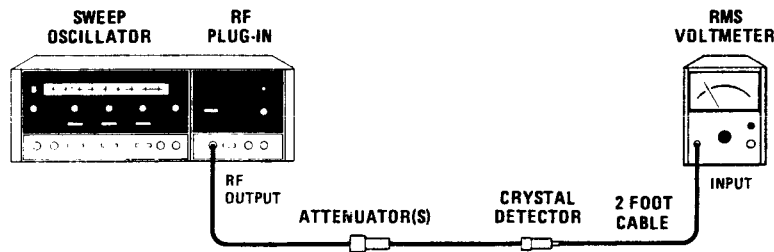

Figure 4-14. Residual AM Test Setup

EQUIPMENT:

- Sweep Oscillator..... HP 8620C
- RMS Voltmeter HP 3400A
- Attenuators (as required) HP 8491A, Options 003, 006, 010, and 020
- Crystal Detector..... HP 423B
- Two-foot cable..... HP 11086A

PROCEDURE:

a. Set controls as follows:

8620C:

- BAND..... Frequency of Plug-in installed
- CW MARKER pointer Center-scale
- 1 kHz SQ WV/OFF (rear panel) OFF
- RF BLANKING/OFF (rear panel) RF BLANKING
- DISPLAY BLANKING/OFF (rear panel) OFF

RF PLUG-IN:

- RF OFF-ON..... ON
- ALC switch OFF or INT
- POWER LEVEL Fully clockwise

b. Press 8620C LINE pushbutton to ON. Press CW pushbutton. Allow 30 minutes warmup time.

PERFORMANCE TESTS

4-15. RESIDUAL AM TEST (Cont'd)

- c. Using a power meter, thermistor mount, and 20 dB attenuator, set the POWER LEVEL control at specified maximum power for RF Plug-in. Disconnect power meter/thermistor mount from 20 dB attenuator. Set 8620C rear-panel SQ WV/OFF switch to 1 kHz SQ WV.
- d. Connect equipment as shown in Figure 4-14 using 20 dB attenuator. Note reading on RMS voltmeter.
- e. Select less or greater attenuation using 3 dB, 6 dB, and 10 dB attenuators until reading on RMS voltmeter is $-28 \text{ dB} \pm 3 \text{ dB}$. Note voltmeter reading.
- f. Set 8620C rear-panel 1 kHz SQ WV/OFF switch to OFF. Change RMS voltmeter range switch to obtain onscale indication. Difference between this indication and indication noted in step d should be a minimum of 41 dB.

NOTE

A 41 dB decrease in the RMS voltmeter indication corresponds to a 50-dB reduction in signal level. A correction factor of 9 dB is added because of the RMS voltmeter response to a square wave and the square-law response of the crystal detector.

4-16. EQUIVALENT SOURCE SWR TEST (Option 001 or standard 86240B)**SPECIFICATION:****Source SWR:**

Leveled: (Option 001 or standard 86240B only): < 1.6

DESCRIPTION:

The output signal is measured using a directional coupler, crystal detector, and oscilloscope. The signal at the oscilloscope contains (1) the initial signal from the oscillator, and (2) the reflected signal. The reflected signal is developed as follows: The original oscillator signal travels down the 20-cm air lines, encounters the open end, and is reflected back to the source. If the reflected signal at the RF OUTPUT connector encounters a perfect 50-ohm source match, no signal is reflected back. However, the greater the mismatch, the greater the reflected signal. This reflected signal either adds to or subtracts from the incident oscillator signal. This variation of the oscillator signal is displayed on the oscilloscope.

PERFORMANCE TESTS

4-16. EQUIVALENT SOURCE SWR TEST (Option 001 or standard 86240B) (Cont'd)

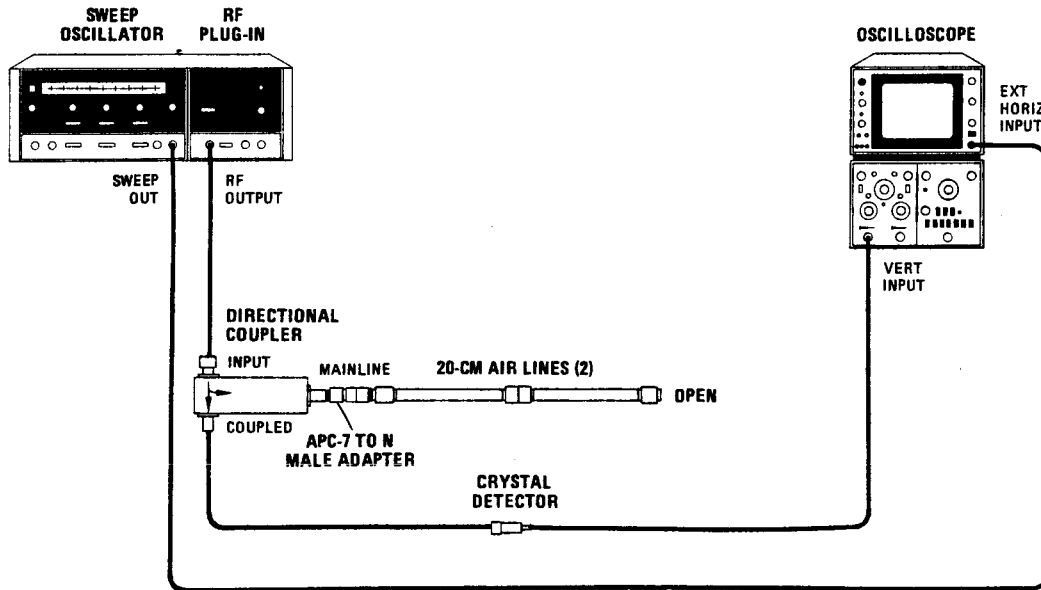

Figure 4-15. Equivalent Source SWR Test Setup

EQUIPMENT:

Sweep Oscillator.....	HP 8620C
Oscilloscope.....	HP 180C/1801A/1820C
Crystal Detector.....	HP 423B
20-cm Air Lines (2).....	HP 11567A
APC7-to-N Male Adapter.....	HP 11525A
Directional Coupler.....	HP 779D

PROCEDURE:

- a. Connect equipment as shown in Figure 4-15.
- b. Set controls as follows:

8620C:

BAND.....	Frequency of Plug-in installed
MARKERS.....	OFF
MODE.....	AUTO
TRIGGER.....	INT
TIME—SECONDS.....	.1 — .01
TIME-SECONDS Vernier.....	Fully clockwise
1 kHz SQ WV/OFF (rear panel).....	OFF
RF BLANKING/OFF (rear panel).....	RF BLANKING
DISPLAY BLANKING/OFF (rear panel).....	OFF

PERFORMANCE TESTS

4-16. EQUIVALENT SOURCE SWR TEST (Option 001 or standard 86240B) (Cont'd)

RF PLUG-IN:

RF OFF-ON ON
 ALC switch INT
 POWER LEVEL Fully clockwise

- c. Press 8620C LINE pushbutton to ON; FULL SWEEP pushbutton should light. Allow 30 minutes warmup time.
- d. Note maximum amplitude on oscilloscope. If greater than -25 mV, adjust POWER LEVEL control counterclockwise for -25 mV maximum peak trace to place crystal detector in square-law output range. (Display should be similar to that shown in Figure 4-16.)
- e. Select points on trace where V_{max} and V_{min} appear to have greatest separation and calculate V_{max}/V_{min} for each point.
- f. Convert greatest V_{max}/V_{min} ratio noted in step e into source match SWR using Figure 4-17.
- g. In internal leveling mode, source match SWR should be < 1.6 .

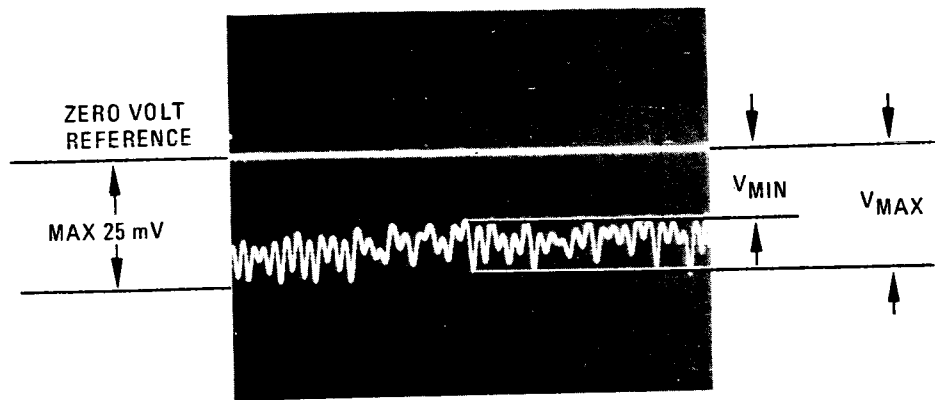

Figure 4-16. Typical Pattern of a Swept SWR Measurement

PERFORMANCE TESTS

4-16. EQUIVALENT SOURCE SWR TEST (Option 001 or standard 86240B) (Cont'd)

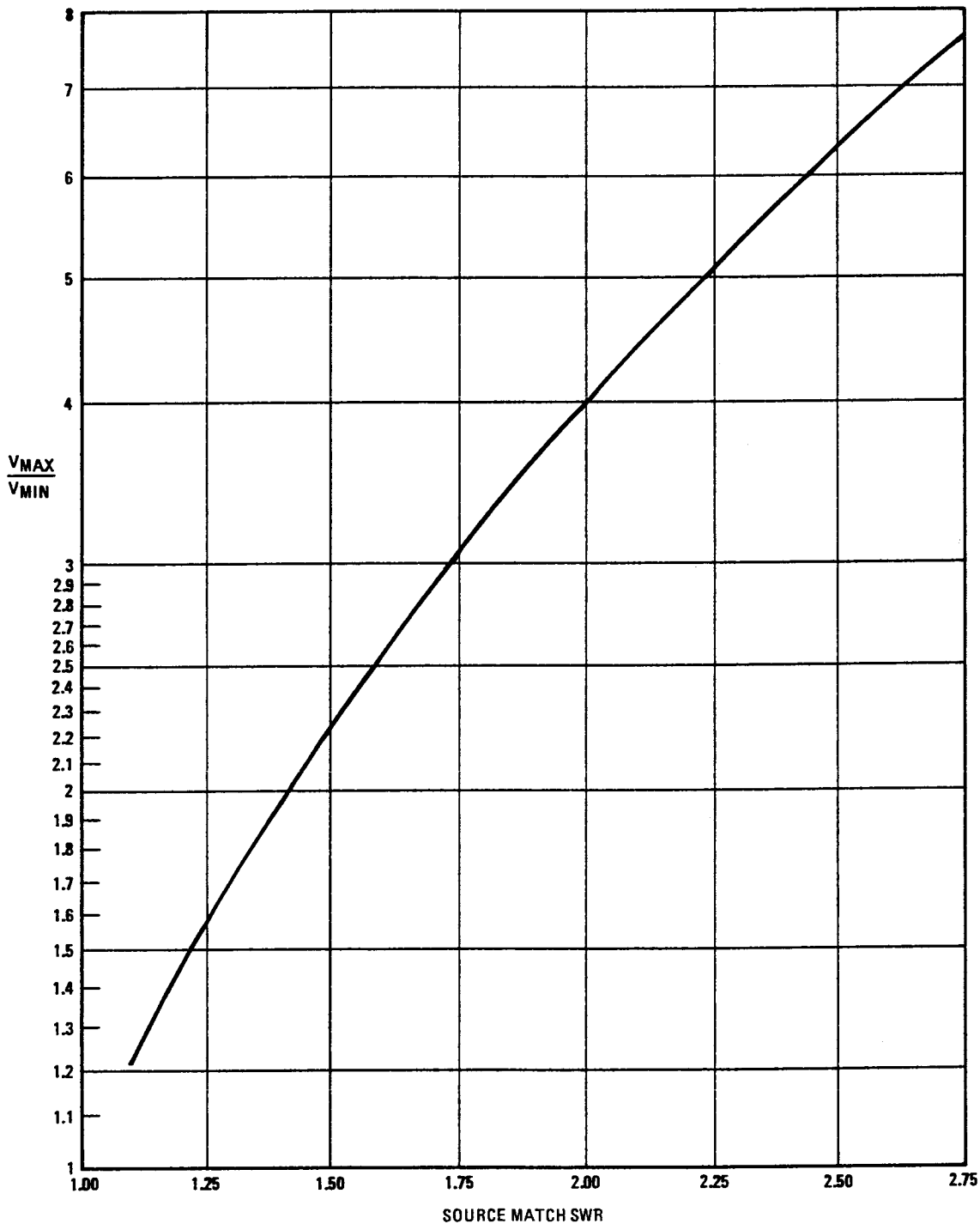

Figure 4-17. Conversion of Oscilloscope Trace to Source Match SWR

PERFORMANCE TESTS

4-17. EXTERNAL FREQUENCY MODULATION TEST

SPECIFICATION:

External FM:

Maximum Deviation for Modulation Frequencies (86240A/B; 86235A without Option 008):

FM-NORM-PL switch in FM or PL:

DC to 100 Hz: ± 75 MHz

DC to 1 kHz: ± 5 MHz

DC to 2 MHz: ± 2 MHz

Maximum Deviation for Modulation Frequencies (86240C; 86235A Option 008):

MLA-NORM switch in MLA:

DC to 100 Hz: ± 150 MHz

90 kHz to 1 MHz: ± 7 MHz

90 kHz to 5 MHz: ± 5 MHz

90 kHz to 10 MHz: ± 1.5 MHz

MLA-NORM switch in NORM:

DC to 100 Hz: ± 12 MHz

DC to 1 kHz: ± 10 MHz

DC to 1 MHz: ± 7 MHz

DC to 5 MHz: ± 5 MHz

DC to 10 MHz: ± 1.5 MHz

DESCRIPTION:

RF output is modulated with an external signal source. The resulting FM deviation is displayed on a spectrum analyzer. Deviations in frequency ranges up to 1 kHz are measured directly on spectrum analyzer. Deviations in frequency ranges from 1 MHz to 10 MHz are calculated using the Bessel null method.

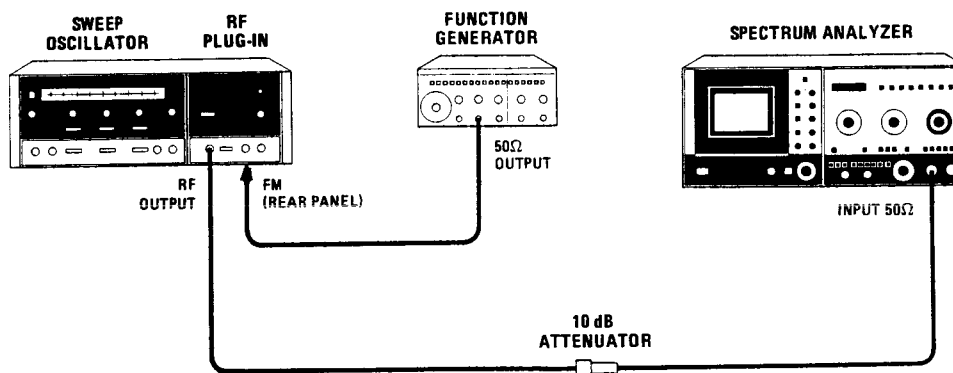

Figure 4-18. External FM Test Setup

PERFORMANCE TESTS

4-17. EXTERNAL FREQUENCY MODULATION TEST (Cont'd)

EQUIPMENT:

Sweep Oscillator.....	HP 8620C
Spectrum Analyzer.....	HP 8565A
Function Generator.....	HP 3312A
20 dB Attenuator.....	HP 8491A, Opt. 010

PROCEDURE:

- a. Connect equipment as shown in Figure 4-18. Press 8620C LINE pushbutton ON. Allow 30 minutes warmup time.
- b. Set controls as follows:

8620C:

BAND.....	Frequency of Plug-in installed
1 kHz SQ WV/OFF (rear panel).....	OFF
DISPLAY BLANKING/OFF (rear panel).....	OFF
RF BLANKING/OFF (rear panel).....	OFF

RF Plug-in:

RF OFF-ON.....	ON
ALC switch.....	OFF or INT
FM-NORM-PL (MLA-NORM) switch.....	FM or PL (MLA)

- c. Press CW pushbutton on 8620C. Set spectrum analyzer to all normal (green) settings. Center fundamental signal on spectrum analyzer CRT display.

NOTE

For 86240A/B and 86235A without MLA, continue with steps d through n immediately following. For 86240C and 86235A with MLA (Option 008), go to text heading for those instruments and perform steps d through v listed there.

86240A/B; 86235A without Option 008

- d. Set function generator frequency to 100 Hz sine wave and adjust its amplitude control slowly clockwise while monitoring display on spectrum analyzer. (Deviation should be linear at first, then become non-linear as deviation increases.)
- e. Note point at which deviation becomes non-linear (i.e., + deviation does not equal - deviation). (See Figure 4-19.) Deviation at this point should be at least ± 75 MHz.
- f. Set function generator amplitude fully counterclockwise and frequency to 1 MHz. Remove BNC cable from function generator 50 Ω output.
- g. Set spectrum analyzer reference level controls so that signal displayed touches top graticule line. Reconnect function generator 50 Ω output to FM input of RF Plug-in.
- h. Increase function generator amplitude control while monitoring spectrum analyzer display. Sidebands will appear and carrier amplitude will start to decrease. Increase function generator amplitude until closest sidebands peak, then null, then peak again (seconds peak of first sidebands).

PERFORMANCE TESTS

4-17. EXTERNAL FREQUENCY MODULATION TEST (Cont'd)

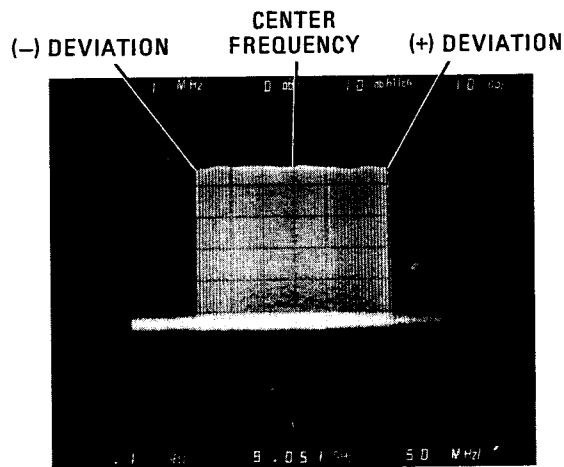

Figure 4-19. Typical Spectrum Analyzer Display of 100 Hz Frequency Deviation

- i. Point noted in step h is point of ± 5 MHz deviation. There should be no great frequency shift or frequency pulling at this point.
- j. Remove BNC cable from function generator 50 Ω output. Set function generator amplitude control fully counterclockwise and frequency to 2 MHz.
- k. Set spectrum analyzer AMPLITUDE SCALE, LOG/DIV to 2 dB and adjust reference level controls so that signal displayed touches top graticule line.
- l. Reconnect function generator 50 Ω output to FM input of RF Plug-in.
- m. Increase function generator amplitude control while monitoring spectrum analyzer display. Sidebands will appear, and carrier amplitude will start to decrease. Increase function generator amplitude until carrier is ≥ 3 dB down from reference level. (See Figure 4-20a.)
- n. Point noted in step m is point of ± 2 MHz deviation. There should be no great frequency shift or frequency pulling at this point.

86240C; 86235A Option 008

- d. Set function generator frequency to 100 Hz sine wave and adjust its amplitude control slowly clockwise while monitoring display on spectrum analyzer. (Deviation should be linear at first, then become non-linear as deviation increases.)
- e. Note point at which deviation becomes non-linear (i.e., + deviation does not equal - deviation). (See Figure 4-19.) Deviation at this point should be at least ± 150 MHz.
- f. Set function generator amplitude control fully counterclockwise and frequency to 1 MHz.
- g. Remove BNC cable from function generator 50 Ω output. Set spectrum analyzer AMPLITUDE SCALE, LOG/DIV to 10 dB and adjust reference level controls so that signal displayed touches top graticule line.

PERFORMANCE TESTS

4-17. EXTERNAL FREQUENCY MODULATION TEST (Cont'd)

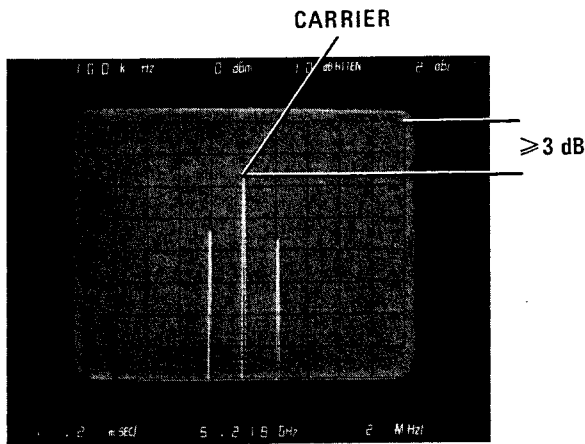

a. ± 2 MHz DEVIATION AT 2 MHz

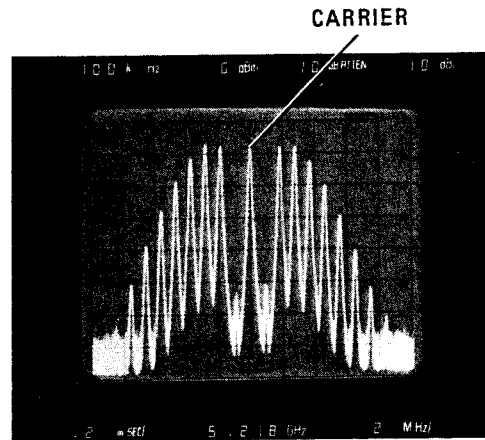

b. ± 7 MHz DEVIATION AT 1 MHz

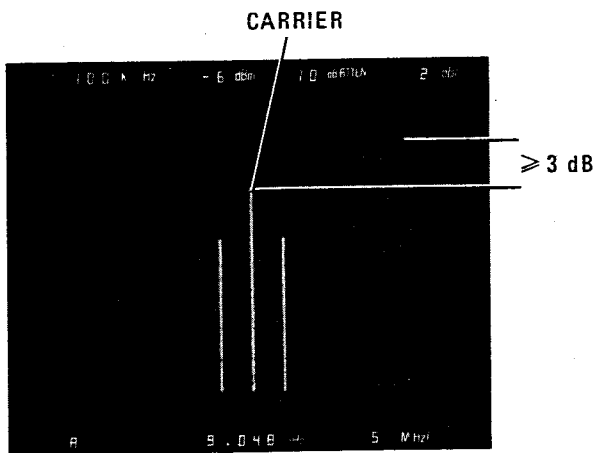

c. ± 5 MHz DEVIATION AT 5 MHz

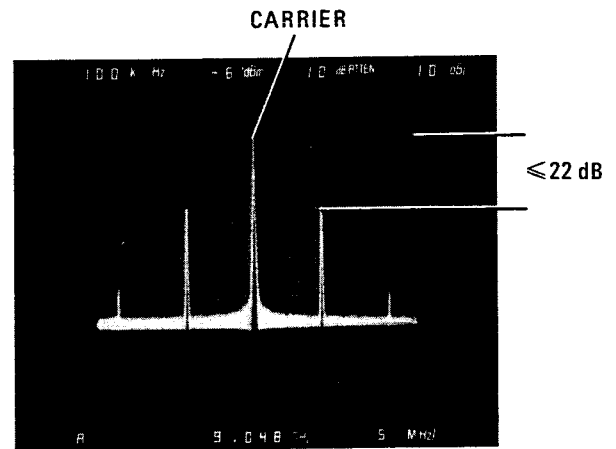

d. ± 1.5 MHz DEVIATION AT 10 MHz

Figure 4-20. FM Deviations at Specified Modulation Frequencies

PERFORMANCE TESTS

4-17. EXTERNAL FREQUENCY MODULATION TEST (Cont'd)

- h. Reconnect function generator 50 Ω output to FM input of RF Plug-in.
- i. Increase function generator amplitude control while monitoring spectrum analyzer display. Sidebands will appear and carrier amplitude will start to decrease. Increase function generator amplitude until carrier goes past second null and then peaks. (See Figure 4-18b.)
- j. Point noted in step i is point of ± 7 MHz deviation. There should be no great frequency shift or frequency pulling at this point.
- k. Set function generator amplitude control fully counterclockwise and frequency to 5 MHz.
- l. Remove BNC cable from function generator, set AMPLITUDE SCALE, LOG/DIV to 2 dB, set signal to top graticule line of CRT, and reconnect cable.
- m. Increase function generator amplitude control while monitoring spectrum analyzer display. Sidebands will appear, and carrier amplitude will start to decrease. Increase function generator amplitude until carrier is ≥ 3 dB down from reference level. (See Figure 4-18c.)
- n. Point noted in step m is point of ± 5 MHz deviation. There should be no great frequency shift or frequency pulling at this point.
- o. Set function generator amplitude control fully counterclockwise and frequency to 10 MHz.
- p. Remove BNC cable from function generator, set AMPLITUDE SCALE, LOG/DIV to 10 dB, set signal to top graticule line of CRT, and reconnect cable.
- q. Increase function generator amplitude while monitoring spectrum analyzer display. Sidebands will appear, and carrier amplitude will start to decrease. Increase function generator amplitude until closest sidebands are ≤ 22 dB down from carrier. (See Figure 4-18d.)
- r. Point noted in step q is point of ± 1.5 MHz deviation. There should be no great frequency shift or frequency pulling at this point.
- s. Set MLA-NORM switch of RF Plug-in to NORM.
- t. Repeat steps d and e of this section, but note that deviation should be at least ± 12 MHz.
- u. Repeat steps d and e of this section, except that function generator frequency is set to 1 kHz. Deviation should be at least ± 10 MHz.
- v. Repeat steps f through r of this section to test the following specifications:

DC to 1 MHz: ± 7 MHz
DC to 5 MHz: ± 5 MHz
DC to 10 MHz: ± 1.5 MHz

PERFORMANCE TESTS

4-18. AMPLITUDE MODULATION TEST

SPECIFICATION:

Internal AM (at specified maximum leveled power):
 1 kHz square wave ON/OFF ratio: > 40 dB

External AM (at specified maximum leveled power):
 Attenuation with +5V input: > 30 dB

External Pulse Modulation (at specified maximum leveled power):
 ON/OFF ratio: > 40 dB
 Square wave response (symmetry): 40/60

DESCRIPTION:

Attenuation is checked by applying +5.0 Vdc and observing corresponding decrease in RF output power (40 dB below maximum leveled power). ON/OFF ratio is checked for both internal AM and external AM. Symmetry is checked for external AM to verify compatibility with HP 8755A/B Swept Amplitude Analyzer.

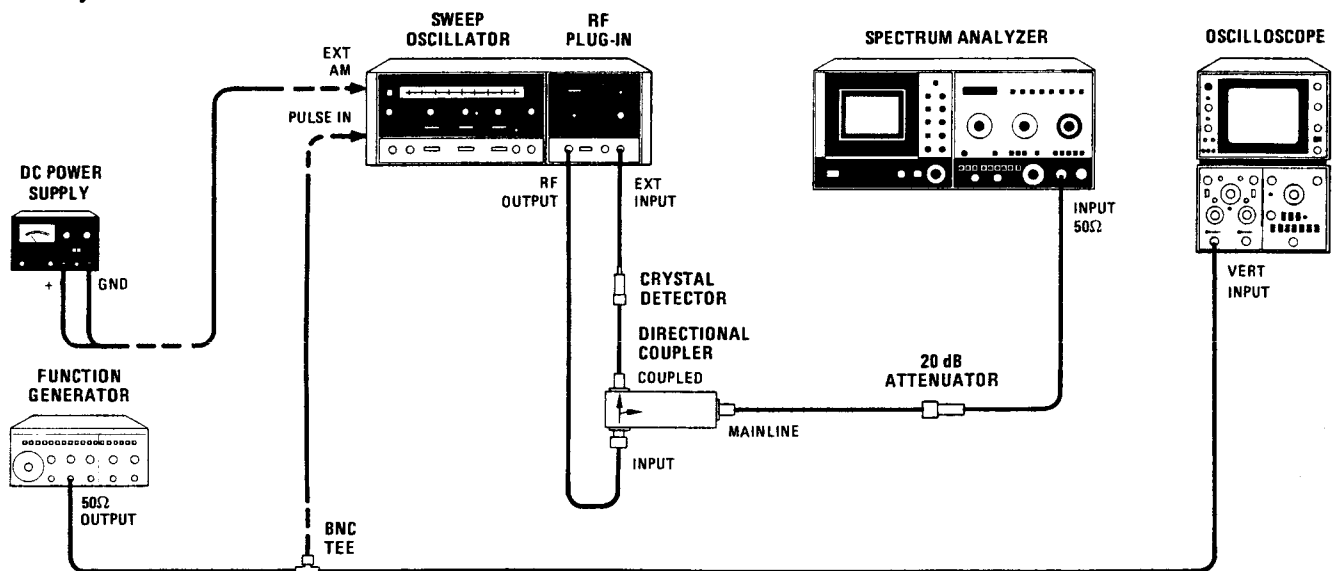

Figure 4-21. Amplitude Modulation Test Setup

EQUIPMENT:

Sweep Oscillator	HP 8620C
Function Generator	HP 3312A
Spectrum Analyzer	HP 8565A
Oscilloscope	HP 180C/1801A/1820C
DC Power Supply	HP 6214A
Crystal Detector	HP 423B
Directional Coupler	HP 779D
20 dB Attenuator	HP 8491 A Option 020

PERFORMANCE TESTS

4-18. AMPLITUDE MODULATION TEST (Cont'd)

PROCEDURE:

- a. Connect equipment as shown in Figure 4-21, with spectrum analyzer connected to 20 dB attenuator and power supply connected to rear-panel EXT AM connector. Press 8620C LINE pushbutton to ON. Allow 30 minutes warmup time.
- b. Set controls as follows:

8620C:
 BAND Frequency of Plug-in installed
 CW MARKER pointer Center scale
 MARKERS OFF
 RF BLANKING/OFF (rear panel) RF BLANKING
 1 kHz SQ WV/OFF (rear panel) OFF
 DISPLAY BLANKING/OFF (rear panel) OFF

RF PLUG-IN:
 RF OFF-ON ON
 ALC switch EXT
 POWER LEVEL Maximum leveled power

8565A:
 FREQUENCY BAND GHz To include mid-band of Plug-in
 RESOLUTION BW 10 kHz
 FREQUENCY SPAN/DIV 20 MHz
 INPUT ATTEN 10 dB
 SWEEP TIME/DIV 5 mSEC
 REF LEVEL 0 dBm
 AMPLITUDE SCALE, LOG/DIV 10 dB
 VIDEO FILTER OFF
 SWEEP SOURCE INT

External AM Sensitivity Checks

- c. Press CW pushbutton on 8620C. Note signal level of fundamental frequency displayed on spectrum analyzer. This is reference level for test.
- d. Adjust external power supply for +5 Vdc output. Output power, as observed on spectrum analyzer, should be > 30 dB below reference.
- e. Disconnect external power supply from 8620C rear-panel EXT AM connector.

27.8 kHz Square Wave External AM

- f. Connect function generator to rear-panel PULSE IN connector and to CH A input of oscilloscope as shown in Figure 4-21. Set function generator for 27.8 kHz square wave and adjust for 6V peak-to-peak output as shown on oscilloscope (10 μSEC/DIV).
 - g. Set spectrum analyzer RESOLUTION BW to 3 MHz, SWEEP TIME/DIV to 5 μSEC, AUTO STABILIZER to OFF, and FREQUENCY SPAN MODE to ZERO.
-

PERFORMANCE TESTS

4-18. AMPLITUDE MODULATION TEST (Cont'd)

- h. Adjust spectrum analyzer TUNING control for maximum signal amplitude on spectrum analyzer display. Set REF LEVEL controls to place signal at top graticule line.
- i. Press spectrum analyzer SWEEP TRIGGER VIDEO pushbutton and adjust TRIGGER LEVEL as necessary. Note difference in power levels of ON and OFF periods of displayed square wave. ON/OFF ratio should be >40 dB (greater than four divisions).
- j. Observe ratio of ON period to OFF period on spectrum analyzer display. ON/OFF symmetry should be >40/60.

1 kHz Square Wave Internal AM

- k. Disconnect function generator from PULSE IN connector and set 8620C rear-panel 1 kHz SQ WV/OFF switch to 1 kHz SQ WV.
- l. Set spectrum analyzer SWEEP TIME/DIV to .2 mSEC and adjust TRIGGER LEVEL as necessary. Adjust spectrum analyzer TUNING control for maximum signal amplitude on display.
- m. Set spectrum analyzer REF LEVEL controls to place top of square wave at top graticule line. Note difference in power levels of ON and OFF periods. ON/OFF ratio should be >40 dB (greater than four divisions).

4-19. FM FREQUENCY RESPONSE TEST
SPECIFICATION:**External FM:**

FM Frequency Response (86240A/B; 86235A without MLA):

PL-NORM-FM switch in FM:

DC to 2 MHz: ± 3 dB

FM Frequency Response (86240C; 86235A with MLA):

MLA-NORM switch in MLA:

DC to 100 Hz: ± 1.5 dB

90 kHz to 10 MHz: ± 1.5 dB

MLA-NORM switch in NORM position:

DC to 10 MHz: ± 1.5 dB

DESCRIPTION:

FM deviation of the RF Plug-in is compared to a known voltage reference using a delay line discriminator, and the difference is measured with an oscilloscope. Since the oscilloscope is calibrated so that four major divisions are equal to 100 percent, each minor division is equal to 5 percent. A difference +41, -29 percent is approximately equal to ± 3 dB, and a difference of +18, -16 percent is approximately equal to ± 1.5 dB.

PERFORMANCE TESTS

4-19. FM FREQUENCY RESPONSE TEST (Cont'd)

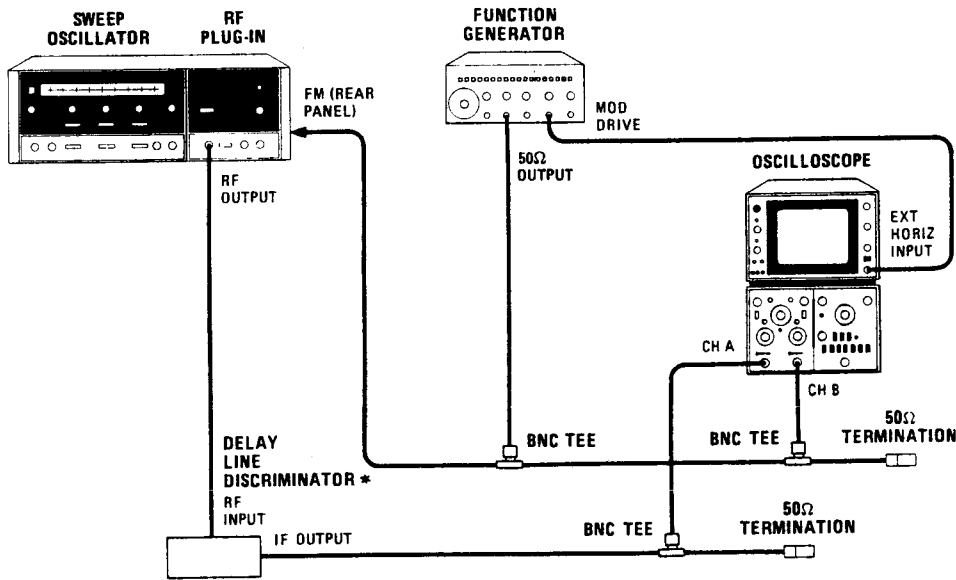

* REFER TO FIGURE 1-5 FOR DETAILS

Figure 4-22. FM Frequency Response Test Setup

EQUIPMENT:

- Sweep Oscillator HP 8620C
- Oscilloscope HP 180C/1801A/1820C
- Function Generator HP 3312A
- Delay Line Discriminator (See Figure 1-5)

PROCEDURE:

- a. Connect equipment as shown in Figure 4-22. Press 8620C LINE switch ON. Allow 30 minutes warmup time.
- b. Set controls as follows:

- 8620C:
- CW MARKER pointer Center scale
 - RF BLANKING/OFF (rear panel) OFF
 - DISPLAY BLANKING/OFF (rear panel) OFF
 - 1 kHz SQ WV/OFF (rear panel) OFF

- RF Plug-in:
- RF OFF-ON ON
 - ALC switch OFF or INT
 - POWER LEVEL Fully clockwise
 - FM-NORM-PL (MLA-NORM) Switch FM (NORM)

PERFORMANCE TESTS

4-19. FM FREQUENCY RESPONSE TEST (Cont'd)

OSCILLOSCOPE:

Horizontal display EXT
 VOLTS/DIV:
 CH A 0.005 (CAL)
 CH B 0.02 (CAL)
 Vertical display CH B
 Input DC

FUNCTION GENERATOR:

RANGE Hz 100
 FREQUENCY 10
 FUNCTION ~
 OFFSET CAL
 SYM. CAL
 MODULATION SWP
 SWP START Fully counterclockwise
 RANGE Hz VERNIER Best display

- c. Press 8620C CW and CW VERNIER pushbuttons.
- d. Adjust function generator AMPLITUDE control for 8 divisions CH B display on oscilloscope.
- e. Select CH A display on oscilloscope.
- f. Vertically center signal on oscilloscope using CW MARKER and CW VERNIER controls.
- g. Using POWER LEVEL, CW MARKER, and CW VERNIER controls, adjust oscilloscope display for 4 divisions centered about center horizontal graticule line.
- h. Select CH B display on oscilloscope.
- i. Using vertical POSITION and VOLTS/DIV CAL knob, adjust oscilloscope CH B display for 4 divisions centered about center horizontal graticule line.
- j. Select CHOP display on oscilloscope.
- k. Set function generator SWP START control to about 2 o'clock position and adjust for stable waveforms on oscilloscope.

NOTE

For 86235A without Option 008 or for 86240A/B, continue with step l. For 86235A Option 008 or for 86240C, continue with step o.

PERFORMANCE TESTS

4-19. FM FREQUENCY RESPONSE TEST (Cont'd)**86235A without MLA; 86240A/B**

1. Using vertical POSITION controls of oscilloscope, adjust the two superimposed waveforms so that they are aligned at the bottom edge at point measured. (See Figure 4-23.) CH A waveform should not be more than 8 minor divisions higher or 6 minor divisions lower than CH B waveform. This indicates approximately +41, -29 percent, or ± 3 dB, since four major divisions represent 100 percent and each minor division represents 5 percent.

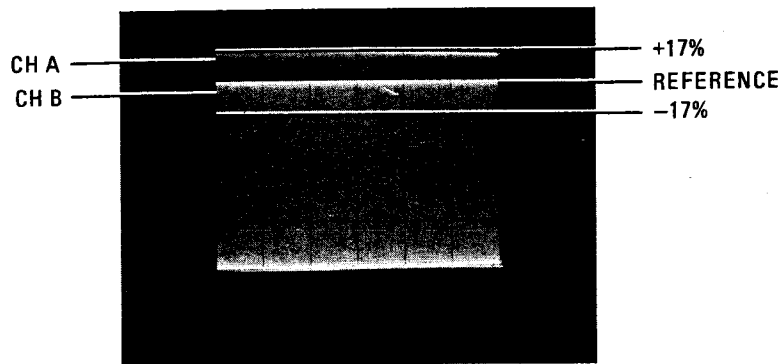

Figure 4-23. FM Frequency Response Waveform

- m. In sequence, press the 1k through 100k RANGE Hz pushbuttons of the function generator. In each position, align the superimposed waveforms and check for a deviation of not more than 8 minor divisions higher or 6 minor divisions lower than CH B waveform.
- n. Set RANGE Hz pushbutton of function generator to 1M and FREQUENCY control to 2. Align superimposed waveforms and check for a deviation of not more than 8 minor divisions higher or 6 minor divisions lower than CH B waveform.

86235A Option 008; 86240C

- o. Using vertical POSITION controls of oscilloscope, adjust the two superimposed waveforms so that they are aligned at the bottom edge at point measured. (See Figure 4-23.) CH A waveform should not be more than 3-1/2 minor divisions higher or lower than CH B waveform. This indicates approximately ± 17 percent, or ± 1.5 dB, since four major divisions represent 100 percent and each minor division represents 5 percent.
 - p. In sequence, press 1k through 1M RANGE Hz pushbuttons of the function generator. In each position, align the superimposed waveforms and check for a deviation of not more than 3-1/2 minor divisions.
 - q. Set MLA-NORM switch (rear panel of RF Plug-in) to MLA position. Set RANGE Hz pushbutton of function generator to 10 and FREQUENCY control to 10. Align superimposed waveforms and check for a deviation of not more than 3-1/2 minor divisions.
 - r. In sequence, press 100k and 1M RANGE Hz pushbuttons of the function generator. In each position, align the superimposed waveforms and check for a deviation of not more than 3-1/2 minor divisions.
-

PERFORMANCE TESTS

4-20. UP CONVERTER SIMULATION TEST (MLA Only)**SPECIFICATION:****86235A Option 008:**

Across 30 MHz sweep width:

Linearity at 277 kHz: $\leq 2\%$ Group delay at 277 kHz: ≤ 2 nsDifferential gain at 5.6 MHz: $\leq 2\%$ Differential phase at 5.6 MHz: ≤ 2 degrees

Across 50 MHz sweep width:

Linearity at 277 kHz: $\leq 3.3\%$ Group delay at 277 kHz: ≤ 3.3 nsDifferential gain at 5.6 MHz: $\leq 3.3\%$ Differential phase at 5.6 MHz: ≤ 3.3 degrees**86240C:**

Across 30 MHz sweep width:

Linearity at 277 kHz: $\leq 0.5\%$ Group delay at 277 kHz: ≤ 1 nsDifferential gain at 5.6 MHz: $\leq 0.5\%$ Differential phase at 5.6 MHz: ≤ 1 degree

Across 50 MHz sweep width:

Linearity at 277 kHz: $\leq 0.83\%$

Group delay at 277 kHz: 1.7 ns

Differential gain at 5.6 MHz: $\leq 0.83\%$ Differential phase at 5.6 MHz: ≤ 1.7 degrees**DESCRIPTION:**

The RF Plug-in is connected as part of a Microwave Link Analyzer (MLA) system, and the MLA is used to check up converter simulation.

PERFORMANCE TESTS

4-20. UP CONVERTER SIMULATION TEST (MLA Only) (Cont'd)

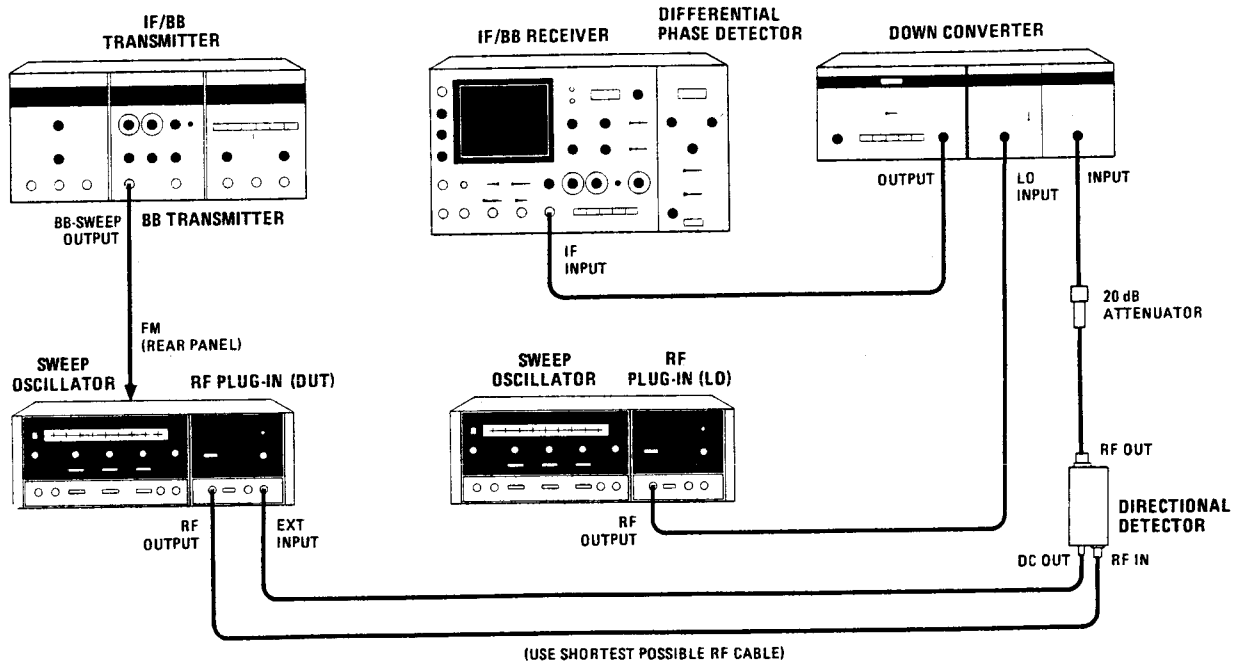

Figure 4-24. Up Converter Simulation Test Setup

EQUIPMENT:

Sweep Oscillator (2 required)	HP 8620C
RF Plug-in	HP 86235A or HP 86240A
IF/BB Transmitter	HP 3710A
BB/Transmitter (Plug-in)	HP 3716A, Option 010
IF/BB Receiver	HP 3702B
Differential Phase Detector (Plug-in)	HP 3705A, Option 010
Down Converter	HP 3730A
External LO Plug-in	HP 37301A
Directional Detector	HP 784B
20 dB Attenuator	HP 8491A, Option 020

PROCEDURE:

- a. Connect equipment as shown in Figure 4-24. Press LINE Pushbutton ON on both 8620C mainframes. Allow 30 minutes warmup time.

PERFORMANCE TESTS

4-20. UP CONVERTER SIMULATION TEST (MLA Only) (Cont'd)

b. Set controls as follows:

8620C: (DUT):

BAND Frequency of Plug-in installed
 CW MARKER pointer Center scale
 RF BLANKING/OFF (rear panel) OFF
 DISPLAY BLANKING/OFF (rear panel) OFF
 1 kHz SQ WV/OFF (rear panel) OFF

RF Plug-in: (DUT):

RF OFF-ON ON
 ALC switch OFF or INT

POWER LEVEL Mid-range
 MLA-NORM switch (rear panel) MLA

8620C (LO)

BAND Frequency of Plug-in installed
 CW MARKER pointer Center scale
 RF BLANKING/OFF (rear panel) OFF
 DISPLAY BLANKING/OFF (rear panel) OFF
 1 kHz SQ WV/OFF (rear panel) OFF

RF Plug-in (LO):

RF OFF-ON ON
 ALC switch OFF or INT
 POWER LEVEL Fully clockwise

8702B/3705A Option 010:

INTENSITY Mid-range
 BLANKING ON
 CALIBRATION OFF
 SWEEP SOURCE INT IF
 X POSITION Mid-position
 Y1 GAIN/POSITION Mid-position
 Y2 GAIN/POSITION Mid-position
 BB POWER (- dBm) 20
 Y1 DISPLAY IF
 ON/OFF IF
 Y1 Y2 CALIBRATION OFF
 MARKERS SLIDING (no COMB)
 MARKER OFFSET Fully counterclockwise
 IF ATTENUATOR 16 dB
 SET LEVEL Mid-position
 BB FREQUENCY 277Δ kHz
 DIFF PHASE CALIBRATION OFF
 BANDWIDTH (kHz) 1

PERFORMANCE TESTS

4-20. UPCONVERTER SIMULATION TEST (MLA Only) (Cont'd)

3710A/3716A Option 010:

SWEeper	INT
OUTPUT LEVEL	1
BB POWER - dBm	18
SWEeP CAL	Fully counterclockwise
BB + SWEeP OUTPUT VERNIER	CAL
BB FREQUENCY	277Δ kHz

- c. Press CW pushbutton on both 8620C mainframes.

MLA Calibration

- d. Set 3730A Down Converter AFC switch to OFF and press IF ATTENUATOR 10 dB pushbutton. Tune the 8620C (LO) for an indication of 70 on the 3730A IF CENTRE MHz meter.

NOTE

If the 3730A EXCESS LEVEL light is lit, reduce RF plug-in POWER LEVEL until light goes out.

- e. Set 3730A Down Converter AFC switch to ON then OFF; IF CENTRE MHz meter indication should stay at 70. If the IF CENTRE MHz meter indication changes, the 8620C (LO) is tuned to an image frequency (twice the IF frequency from the RF input frequency); tune the 8620C (LO) to a different frequency and repeat steps d and e.
- f. Adjust RF Plug-in POWER LEVEL for a 0 dB indication on the 3702B IF/BB Receiver IF/BB LEVEL meter. The 3702B IF UNCAL light should not be lit. If necessary, change IF ATTENUATION setting for correct indication.
- g. Set 3702B Y1 DISPLAY switch to BB and adjust the 3716A BB + SWEeP OUTPUT VERNIER for a 0 dB indication on the 3702B IF/BB LEVEL meter. If necessary, change 3716A BB POWER attenuator setting to obtain correct meter indication.
- h. Adjust 3705A PHASE LOCK control for a full right deflection of the PHASE LOCK/LEVEL meter pointer.
- i. Adjust 3705A SET LEVEL control to center the PHASE LOCK/LEVEL meter indication in the green region.
- j. Repeat steps h and i until no further adjustment is necessary.
- k. Adjust 3702B X GAIN and X POSITION controls for a 10-division wide CRT trace horizontally centered on the graticule display.
-

PERFORMANCE TESTS

4-20. UPCONVERTER SIMULATION TEST (MLA Only) (Cont'd)

NOTE

The following procedures measure linearity, group delay, differential gain, and differential phase of the RF Plug-in output at only one CW frequency ± 15 MHz and ± 25 MHz. These procedures should be repeated for each narrow band of interest.

Linearity

- l. Set 3702B MARKER OFFSET switch to ± 15 MHz (30 MHz sweep width).
- m. Adjust 3716A SWEEP CAL control to place the plus and minus 15 MHz markers at each edge of the CRT graticule display.
- n. Set the 3702B BLANKING switch to OFF and adjust X PHASE SHIFT control so the normal trace and retrace marker pulses coincide. Reset BLANKING switch to the ON position.
- o. Set 3702B Y1 Y2 CALIBRATION switch to 1% position and adjust Y1 GAIN control for a one division envelope on CRT display. Reset Y1 Y2 CALIBRATION switch to the OFF position.
- p. Note worst point of linearity and slope of trace. (Downward slope from left to right is negative (–) linearity and upward slope is positive (+) linearity.) Tune 8620C (LO) to opposite side of RF signal. If LO was tuned to 70 MHz below RF signal, tune LO 70 MHz above RF signal (and conversely).
- q. Note worst point of linearity and slope of trace (positive or negative). Algebraically subtract the measurement noted in step p from the measurement noted in step q and divide the result by 2.

Examples: 1. Linearity worst points of +0.5% and –0.3% measured in steps p and q:

$$\frac{+0.5\% - (-0.3\%)}{2} = 0.4\%$$

2. Linearity worst points of +0.5% and +0.7% measured in steps p and q:

$$\frac{+0.5\% - (+0.7\%)}{2} = -0.1\%$$

- r. Corrected linearity should be less than or equal to 2% for 86235A (Option 008) or 0.5% for 86240C.
- s. Set 3702B MARKER OFFSET switch to ± 25 MHz (50 MHz sweep width).
- t. Adjust 3716A SWEEP CAL control to place the plus and minus 25 MHz markers at each edge of the CRT graticule display.
- u. Repeat steps n through q. Corrected linearity should be less than or equal to 3.3% for 86235A (Option 008) or 0.83% for 86240C.

Group Delay

- v. Set 3702B MARKER OFFSET switch to ± 15 MHz (30 MHz sweep width).
- w. Adjust 3716A SWEEP CAL control to place plus and minus 15 MHz markers at each edge of the CRT graticule display.

PERFORMANCE TESTS

4-20. UPCONVERTER SIMULATION TEST (MLA Only) (Cont'd)

- x. Set the 3702B BLANKING switch to OFF and adjust X PHASE SHIFT control so the normal trace and retrace marker pulses coincide. Reset BLANKING switch to the ON position.
- y. Set the 3702B Y2 DISPLAY switch to DELAY and set the 3705A DIFF PHASE CALIBRATION switch to 1 ns. Adjust Y2 GAIN control for a one division envelope on CRT display. Reset DIFF PHASE CALIBRATION switch to the OFF position.
- z. Note maximum group delay and slope of trace. (Downward slope from left to right is negative (-) group delay and upward slope is positive (+) group delay.) Tune 8620C (LO) to opposite side of RF signal. (If LO was tuned 70 MHz below RF signal, tune LO 70 MHz above RF signal and conversely.)
- aa. Note maximum group delay and slope of trace (positive or negative). Algebraically subtract the group delay noted in step z from the group delay noted in step aa and divide by 2. Refer to previous examples following step q.
- ab. Corrected group delay should be less than or equal to 2 ns for 86235A (Option 008) or 1 ns for 86240C.
- ac. Set 3702B MARKER OFFSET switch to ± 25 MHz (50 MHz sweep width).
- ad. Adjust 3716A SWEEP CAL control to place the plus and minus 25 MHz markers at each edge of the CRT graticule display.
- ae. Repeat steps x through aa. Corrected group delay should be less than or equal to 3.3 ns for 86235A (Option 008) or 1.7 ns for 86240C.

Differential Gain

af. Set controls as follows:

3702B/3705A Option 010:
 BB POWER (- dBm) 12
 MARKER OFFSET Fully counterclockwise
 BB FREQUENCY 5.6 MHz

3710A/3716A Option 010:
 BB POWER (- dBm) 14
 BB FREQUENCY 5.6 MHz

- ag. Repeat MLA Calibration (steps d through k).
- ah. Set 3702B MARKER OFFSET switch to ± 15 MHz (30 MHz sweep width).
- ai. Adjust 3716A SWEEP CAL control to place the plus and minus 15 MHz markers at each edge of the CRT graticule display.
- aj. Set the 3702B BLANKING switch to OFF and adjust X PHASE SHIFT control so the normal trace and retrace marker pulses coincide. Reset BLANKING switch to the ON position.
- ak. Set the 3702B Y1 Y2 CALIBRATION switch to 1% and set Y1 GAIN control for a one division envelope on CRT display. Reset Y1 Y2 CALIBRATION switch to the OFF position.

PERFORMANCE TESTS

4-20. UP CONVERTER SIMULATION TEST (MLA Only) (Cont'd)

- al. Note maximum differential gain and slope of trace. (Downward slope from left to right is negative (–) differential gain and upward slope is positive (+) differential gain.) Tune 8620C (LO) to opposite side of RF signal.
- am. Note maximum differential gain and slope of trace (positive or negative). Algebraically subtract the differential gain noted in step al from the differential gain noted in step am and divide by two (2). Refer to previous examples following step q.
- an. Corrected differential gain should be less than or equal to 2% for 86235A (Option 008) or 0.5% for 86240C.
- ao. Set 3702B MARKER OFFSET switch to ± 25 MHz (50 MHz sweep width).
- ap. Adjust 3716A SWEEP CAL control to place the plus and minus 25 MHz markers at each edge of the CRT graticule display.
- aq. Repeat steps aj through am. Corrected differential gain should be less than or equal to 3.3% for 86235A (Option 008) or 0.83% for 86240C.

Differential Phase

- ar. Set 3702B MARKER OFFSET switch to ± 15 MHz (30 MHz sweep width).
- as. Adjust 3716A SWEEP CAL control to place the plus and minus 15 MHz markers at each edge of the CRT graticule display.
- at. Set the 3702B BLANKING switch to OFF and adjust X PHASE SHIFT control so the normal trace and retrace marker pulses coincide. Reset BLANKING switch to the ON Position.
- au. Set the 3702B Y2 DISPLAY to DELAY and set the 3705A DIFF PHASE CALIBRATION switch to 1°. Adjust Y2 GAIN control for a one division envelope on CRT display. Reset DIFF PHASE CALIBRATION switch to OFF position.
- av. Note maximum differential phase and slope of trace. (Downward slope from left to right is negative (–) differential phase and upward slope is positive (+) differential phase.) Tune 8620C (LO) to opposite side of RF signal.
- aw. Note maximum differential phase and slope of trace (positive or negative). Algebraically subtract the differential phase noted in step av from the differential phase noted in step aw and divide by 2. Refer to previous examples following step q.
- ax. Corrected differential phase should be less than or equal to 2 degrees for 86235A (Option 008) or 1 degree for 86240C.
- ay. Set 3702B MARKER OFFSET switch to ± 25 MHz (50 MHz sweep width). Adjust 3716A SWEEP CAL control to place the plus and minus 25 MHz markers at each edge of the CRT graticule display.
- az. Repeat steps at through aw. Corrected differential phase should be less than or equal to 3.3 degrees for 86235A (Option 008) or 1.7 degrees for 86240C.

SECTION V ADJUSTMENTS

5-1. INTRODUCTION

5-2. This section provides adjustment procedures for the Model 86235A/86240A/B/C RF Plug-ins. **These procedures should not be performed as a routine maintenance procedure**, but should be used after replacement of a part or component or when performance tests show that the specifications of Table 1-1 cannot be met. Before attempting any adjustment, allow 30 minutes warm-up time for the instrument. Table 5-1 lists the adjustment controls and the function of each control.

5-3. EQUIPMENT REQUIRED

5-4. Table 1-4 lists the equipment required for the adjustment procedures. If the test equipment recommended is not available, other equipment may be used if its performance meets the "Critical Specifications" listed in the table. The test setup used for an adjustment procedure is referenced in each procedure.

5-5. FACTORY SELECTED COMPONENTS

5-6. Factory selected components can be recognized by an asterisk on the schematic diagram. Selection of these component values is covered in the adjustment procedures.

5-7. SAFETY CONSIDERATIONS

5-8. Although this instrument has been designed in accordance with international safety standards, this manual contains information, cautions, and warnings which must be followed to ensure safe operation and to retain the instrument in safe condition. Service and adjustments should be performed only by qualified service personnel.

WARNING

Any interruption of the protective (grounding) conductor (inside or outside the instrument) or disconnecting the protective earth terminal could make this instrument dangerous.

5-9. Any adjustment, maintenance, and repair of the opened instrument under voltage should be avoided as much as possible, but when required, should be performed only by skilled persons who are aware of the hazard involved.

5-10. Capacitors inside the instrument may still be charged even if the instrument has been disconnected from its source of supply.

5-11. Make sure that only fuses with the required rated current and of the specified type (normal blow, time delay, etc.) are used for replacement. The use of repaired fuses and the shortcircuiting of fuseholders should be avoided.

5-12. Whenever it is likely that the protection offered by fuses has been impaired, the instrument should be made inoperative and secured against any unintended operation.

WARNING

Adjustments described herein are performed with power supplied to the instrument while protective covers are removed. Energy available at many points may, if contacted, result in personal injury.

5-13. LOCATION OF TEST POINTS AND ADJUSTMENTS

5-14. For location of adjustments and test points, refer to Figure 5-14 and 5-15.

Table 5-1. Controls Listed in Adjustment Sequence

Adjustment Paragraph	Schematic Name	Reference Designation	Function Adjusted
5-15	ES1	A3R5	YIG Bias Voltage low break point
5-15	EVL	A3R6	YIG Bias Voltage low end
5-15	EVH	A3R7	YIG Bias Voltage high end
5-15	ES2	A3R8	YIG Bias Voltage high break point
5-16	FL	A3R3	YIG Driver frequency (low end)
5-16	FH	A3R4	YIG Driver frequency (high end)
5-17	FRL	A3R1	Frequency Reference Low
5-17	FRH	A3R2	Frequency Reference High
5-18	TOS	A3R9	YIG Filter Tracking low end
5-18	TS1	A3R10	YIG Filter Tracking mid-band
5-18	TB	A3R11	YIG Filter Tracking high mid-band
5-18	TS2	A3R12	YIG Filter Tracking high end
5-18	GATE	A4A1R4	YIG Oscillator GATE bias
5-18	DRAIN	A6R17	Amplifier DRAIN bias
5-18	1	A6R10	Amplifier GATE 1 bias
5-18	2	A6R11	Amplifier GATE 2 bias
5-18	3	A6R12	Amplifier GATE 3 bias
5-19	OS	A2R18	ALC offset
5-19	HI	A2R10	Power Level control calibration
5-19	LD	A2R58	Power Level control calibration
5-19	LO	A2R15	Power Level control calibration
5-19	GAIN	A2R32	ALC Sample and hold
5-19	SLP	A2R5	ALC internal slope
5-20	OS	A1R3	FM offset
5-20	LFG	A1R1	Low Frequency FM sensitivity
5-20	LFG	A1R11	Low Frequency FM (Option 008 or 86240C Only)
5-20	HFG	A1R2	High Frequency FM sensitivity
5-21	P1	A1R28	FM Frequency Response (low freq)
5-21	P2	A1R27	FM Frequency Response (mid freq)
5-21	Q	A1R15	FM Frequency Response (high freq)

Table 5-2. Factory Selected Components

Reference Designator	Adjustment Paragraph	Service Sheet	Performance Test	Basis of Selection
A1C13 (86240C, 86235A Opt. 008 only)		3		Present in 86235A Option 008; not present in 86240C.
A3C3	5-16	5	4-8	Selected for minimum YIG time delay at high end of band.
A3C19 (86240B only)	5-16	5		Selected for minimum power change with change in sweep time.
A3R31 (86240A/ B/C only)	5-16	5		Selects breakpoint, in conjunction with A3R53, for proper YIG linearity.
A3R53 (86240A/ B/C only)	5-16	5		Selects breakpoint, in conjunction with A3R31, for proper YIG linearity.
A3R67	5-16	5	4-8	Selected for minimum YIG time delay at low end of band.

ADJUSTMENTS

5-15. YIG OSCILLATOR BIAS ADJUSTMENT (86240A/B/C ONLY)

REFERENCE:

A3 YIG Driver Assembly Schematic (See Figure 5-15 for test point and adjustment locations.)

DESCRIPTION:

The YIG oscillator bias level is set to voltages stamped on the oscillator module at the band ends and the voltage is sloped down to break points at frequencies stamped on the oscillator module.

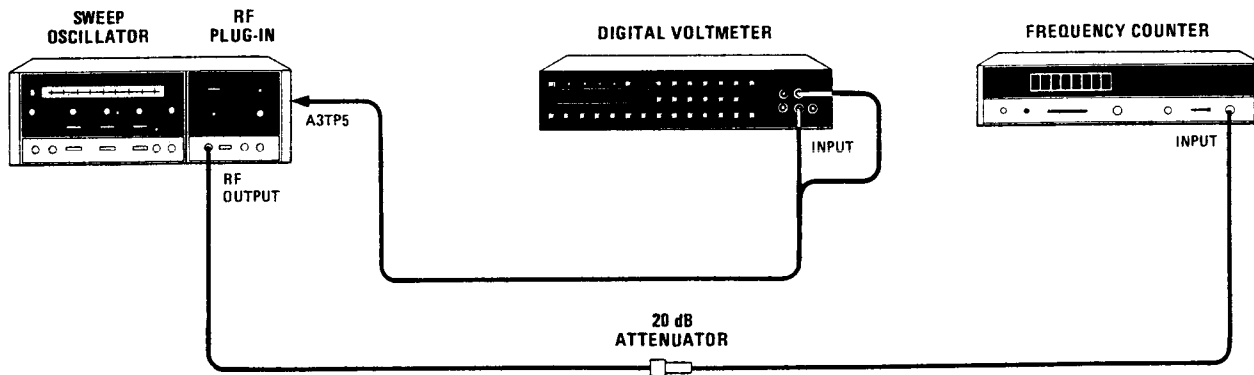

Figure 5-1. YIG Oscillator Bias Adjustment Test Setup

ADJUSTMENTS

5-15. YIG OSCILLATOR BIAS ADJUSTMENT (86240A/B/C ONLY) (Cont'd)

EQUIPMENT:

Sweep Oscillator.....	HP 8620C
Frequency Counter.....	HP 5340A
Digital Voltmeter.....	HP 3455A
20 dB Attenuator.....	HP 8491A, Option 020

PROCEDURE:

1. Connect equipment as shown in Figure 5-1.
2. Set controls as follows:

8620C:

CW MARKER pointer.....	Low frequency end of scale
MODE.....	MANUAL
MANUAL.....	Fully clockwise
TRIGGER.....	INT
TIME-SECONDS.....	.1 - .01
TIME-SECONDS Vernier.....	Fully clockwise

RF PLUG-IN:

RF OFF-ON.....	ON
POWER LEVEL.....	Mid-range

3. Record values stamped on YIG oscillator module for V_L , F_L , V_H , and F_H .

V_L _____ volts	V_H _____ volts
F_L _____ GHz	F_H _____ GHz

4. Press 8620C LINE pushbutton ON. Press CW and CW VERNIER pushbuttons and allow 30 minutes warm-up time.

NOTE

Do NOT attempt the following adjustment unless the A4 YIG Oscillator Assembly or A3 YIG Driver Assembly has been replaced.

5. Bias Adjustment
 - a. Adjust CW MARKER and CW VERNIER controls for a frequency counter indication of 2.000 \pm 0.001 GHz (3.600 \pm 0.001 GHz for 86240C).
 - b. Adjust A3R6 (EVL) for DVM indication of voltage V_L recorded in step 3 \pm 0.001 volt.
 - c. Adjust CW MARKER and CW VERNIER controls for a frequency counter indication of frequency F_L recorded in step 3 \pm 0.001 GHz.
 - d. Adjust A3R5 (ES1) maximum counterclockwise, then rotate slowly clockwise while observing the DVM indication. Set A3R5 (ES1) at the point where the DVM indication just starts to change (greater than 0.01 volt change).

ADJUSTMENTS

5-15. YIG OSCILLATOR BIAS ADJUSTMENT (86240A/B/C ONLY) (Cont'd)

- e. Repeat steps 5a through 5d until no further adjustment is necessary.
- f. Adjust CW MARKER and CW VERNIER controls for a frequency counter indication of 8.400 ± 0.001 GHz (8.600 ± 0.001 GHz for 86240C).
- g. Adjust A3R7 (EVH) for a DVM indication of voltage V_H recorded in step 3 ± 0.01 volt.
- h. Adjust CW MARKER and CW VERNIER controls for a frequency counter indication of frequency F_H recorded in step 3 ± 0.001 GHz.
- i. Adjust A3R8 (ES2) maximum counterclockwise, then rotate slowly clockwise while observing the DVM indication. Set A3R8 (ES2) at the point where the DVM indication just starts to change (greater than 0.01 volt change).
- j. Repeat steps 5f through 5i until no further adjustment is necessary.

5-16. YIG DRIVER FREQUENCY ADJUSTMENTS

REFERENCE:

A3 YIG Driver Assembly Schematic (See Figure 5-15 for test point and adjustment locations.)

DESCRIPTION:

Frequency accuracy is adjusted across the band by adjusting FL and FH controls to corresponding tuning voltages at low, and high end of frequency band.

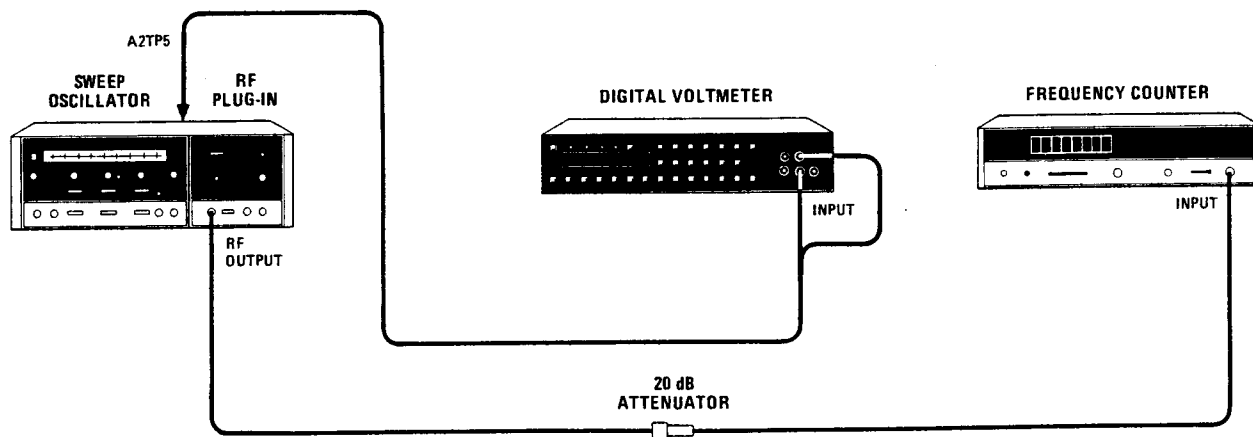

Figure 5-2. YIG Driver Frequency Adjustments Test Setup

ADJUSTMENTS

5-16. YIG DRIVER FREQUENCY ADJUSTMENTS (Cont'd)

EQUIPMENT:

Sweep Oscillator	HP 8620C
Frequency Counter	HP 5340A
Digital Voltmeter	HP 3455A
20 dB Attenuator	HP 8491A, Option 020

PROCEDURE:

1. Connect equipment as shown in Figure 5-2.
2. Set controls as follows:
 - 8620C:
 - CW MARKER pointer Low frequency end of scale
 - CW VERNIER control Fully clockwise
 - CW VERNIER multiplier X1
 - MODE MANUAL
 - MANUAL Fully clockwise
 - TRIGGER INT
 - TIME-SECONDS1 - .01
 - TIME-SECONDS Vernier Fully clockwise
 - RF PLUG-IN:
 - RF OFF-ON ON
 - POWER LEVEL Fully clockwise
3. Press 8620C LINE Pushbutton ON; Allow 30 minutes warm-up time.
4. Connect DVM to A1TP4 (86240A/B and 86235A without Option 008 only).
5. Adjust A1R3 (OS) for $-9.0V \pm 0.1V$ at A1TP4 (except 86240C, 86235A Option 008).
6. Press 8620C CW pushbutton.
7. Connect DVM to 8620C A2TP5. Connect ground lead to 8620C A4 GND.
8. Adjust CW MARKER and CW VERNIER controls for DVM indication of $0.000V \pm 0.005V$.
9. Adjust A3R3 (FL) for a low end frequency counter indication shown in Table 5-3.
10. Adjust CW MARKER and CW VERNIER controls for DVM indication of $10.000V \pm 0.005V$.
11. Adjust A3R4 (FH) for a high end frequency counter indication shown in Table 5-3.

ADJUSTMENTS

5-16. YIG DRIVER FREQUENCY ADJUSTMENTS (Cont'd)

Table 5-3. Frequency End Points

RF Plug-in	Low end of Band	High end of Band
86235A	1.7 GHz	4.3 GHz
86240A	2.0 GHz	8.4 GHz
86240B	2.0 GHz	8.4 GHz
86240C	3.6 GHz	8.6 GHz

12. Selecting value for A3C3. This procedure is necessary only if A4 Oscillator Assembly or A3 YIG Driver Assembly has been replaced.

- a. If A3R67 is missing, solder a 5K resistor in its place.
- b. Connect frequency meter (HP 537A), crystal detector (HP 423B) and oscilloscope (HP 180C/1801A/182C) to RF OUTPUT. Refer to Figure 4-2. (Directional coupler and frequency counter not required.)
- c. Set controls as follows:

8620C:

MODE..... AUTO
 TRIGGER..... INT
 TIME-SECONDS..... 1-01
 1 KHz SQ WV/OFF (rear panel)..... OFF
 RF BLANKING/OFF (rear panel)..... RF BLANKING
 DISPLAY BLANKING/OFF (rear panel)..... OFF

RF PLUG-IN:

RF OFF-ON..... ON
 ALC switch..... OFF or INT
 POWER LEVEL..... Fully clockwise

- d. Press 8620C LINE pushbutton to ON and press FULL SWEEP pushbutton.
- e. Set frequency meter so "pip" is near high end of band.
- f. Adjust 8620C TIME-SECONDS Vernier control fully clockwise, then fully counterclockwise, noting frequency shift of "pip" on CRT display.
- g. Select A3C3 for minimum frequency shift with a full-range change of the TIME-SECONDS Vernier control. See Table 5-4 for range of values and HP Part Numbers.

Table 5-4. Typical Values and HP Part Numbers for A3C3

Value (μF)	HP Part Number
.027	0170-0066
.033	0160-0163
.039	0160-0164
.047	0170-0040

ADJUSTMENTS

5-16. YIG DRIVER FREQUENCY ADJUSTMENTS (Cont'd)

13. Selecting value for A3R67. This procedure is necessary only if A4 Oscillator Assembly or A3 YIG Driver Assembly has been replaced.
 - a. Replace A3R67 with a 100K potentiometer.
 - b. Repeat steps 12b through 12d using an HP 536A in place of HP 537A.
 - c. Set frequency meter so "pip" is near low end of band.
 - d. Adjust 8620C TIME-SECONDS Vernier control fully clockwise, then fully counterclockwise, noting frequency shift of "pip" on CRT display.
 - e. Adjust 100K potentiometer for minimum frequency shift with a full-range change of the TIME-SECONDS Vernier control.
 - f. Carefully remove the 100K potentiometer and measure the resistance with an ohmmeter. Select the closest standard value resistor (see Table 5-5) to use for A3R67.

Table 5-5. Typical Values and HP Part Numbers for A3R67

Value (K Ω)	HP Part Number
9.09	0757-0288
10.0	0757-0442
11.0	0757-0443
12.1	0757-0444
13.3	0757-0289
14.7	0698-3156

14. Selecting value for A3C19 (86240B only). This procedure is necessary only if A4 Oscillator Assembly or A3 YIG Driver Assembly has been replaced.
 - a. Repeat steps 12b through 12d.
 - b. Adjust 86240B POWER LEVEL control for leveled output.
 - c. Adjust 8620C TIME-SECONDS Vernier control fully clockwise, then fully counterclockwise, noting change in power level.
 - d. Select value for A3C19 (from Table 5-6) that provides minimum change in power level with a full-range change of the TIME-SECONDS Vernier control.

Table 5-6. Typical Values and HP Part Numbers for A3C19

Value (μ F)	HP Part Number
.015	0160-0194
.018	0160-0302
.022	0160-0162

ADJUSTMENTS

5-16. YIG DRIVER FREQUENCY ADJUSTMENTS (Cont'd)

15. Selecting values for A3R31 and A3R53 (86240A/B/C only).
 - a. Connect equipment as shown in Figure 5-2. (Digital voltmeter is connected to 8620C A2TP5.)
 - b. Press 8620C LINE pushbutton to ON and press CW and CW VERNIER pushbuttons.
 - c. Set CW and CW VERNIER controls to tuning voltages indicated in Table 5-7 and record actual frequency for each voltage setting.
 - d. Calculate the ΔF (difference between theoretical and actual frequency) for each setting.
 - e. Determine the greatest ΔF and tuning voltage where it appears (Tables 5-7).

Table 5-7. Frequency Versus Tuning Voltage

Tuning Voltage (V \pm .01V)	Theoretical Frequency (GHz)		Actual Frequency (GHz)	ΔF^* (MHz)
	86240A/B	86240C		
6.00	5.840	6.600		
6.50	6.160	6.850		
7.00	6.480	7.100		
7.50	6.800	7.350		
8.00	7.120	7.600		
8.50	7.440	7.850		
9.00	7.760	8.100		
9.50	8.080	8.350		
10.00	8.400	8.600		

*Difference between theoretical and actual frequency.

- f. Using Table 5-8 for 86240A, Table 5-9 for 86240B, or Table 5-10 for 86240C, determine the values for A3R31 and A3R53.
- g. Table 5-11 lists standard values and HP Part Numbers for A3R31 and A3R53.

ADJUSTMENTS

5-16. YIG DRIVER FREQUENCY ADJUSTMENTS (Cont'd)

Table 5-8. 86240A Values for A3R31 and A3R53

Tuning Voltage (V)	Value Pairs for A3R31 and A3R53							
	8.0 MHz Δ F		10.0 MHz Δ F		12.0 MHz Δ F		14.0 MHz Δ F	
	R31	R53	R31	R53	R31	R53	R31	R53
7.00	12.1K	11.0K	10.0K	8.25K	8.25K	7.50K	6.81K	6.19K
7.50	10.0K	10.0K	8.25K	8.25K	6.81K	6.81K	5.62K	5.62K
8.00	8.25K	9.09K	6.81K	7.50K	5.62K	6.19K	4.64K	5.11K
8.50	6.19K	7.50K	5.11K	6.19K	4.22K	5.11K	3.48K	4.22K
9.00	4.22K	5.62K	3.48K	4.64K	2.87K	3.83K	2.37K	3.16K

Table 5-9. 86240B Values for A3R31 and A3R53

Tuning Voltage (V)	Value Pairs for A3R31 and A3R53									
	8.0 MHz Δ F		10.0 MHz Δ F		12.0 MHz Δ F		14.0 MHz Δ F		16.0 MHz Δ F	
	R31	R53	R31	R53	R31	R53	R31	R53	R31	R53
7.00	10.0K	13.3K	7.50K	11.0K	6.81K	9.09K	5.62K	7.50K	5.11K	6.81K
7.50	8.25K	13.3K	6.81K	10.0K	5.62K	8.25K	4.64K	7.50K	4.22K	6.19K
8.00	6.81K	12.1K	5.62K	10.0K	4.64K	8.25K	3.83K	6.81K	3.48K	6.19K
8.50	5.11K	11.0K	4.22K	8.25K	3.48K	6.81K	2.87K	6.19K	2.61K	5.11K
9.00	3.48K	8.25K	2.87K	6.81K	2.37K	5.62K	1.96K	4.64K	1.78K	4.22K

Table 5-10. 86240C Values for A3R31 and A3R53

Tuning Voltage (V)	Value Pairs for A3R31 and A3R53									
	8.0 MHz Δ F		10.0 MHz Δ F		12.0 MHz Δ F		14.0 MHz Δ F		16.0 MHz Δ F	
	R31	R53	R31	R53	R31	R53	R31	R53	R31	R53
7.00	8.25K	9.09K	6.81K	7.50K	5.62K	6.19K	4.64K	5.11K	4.22K	4.64K
7.50	7.50K	9.09K	5.62K	6.81K	5.11K	5.62K	4.22K	5.11K	3.83K	4.22K
8.00	6.19K	7.50K	4.64K	6.19K	3.83K	5.11K	3.48K	4.64K	2.87K	3.83K
8.50	4.64K	6.19K	3.38K	5.11K	3.16K	4.22K	2.61K	3.83K	2.37K	3.16K
9.00	3.16K	4.64K	2.61K	3.83K	2.15K	3.16K	1.78K	2.87K	1.62K	2.37K

ADJUSTMENTS

5-16. YIG DRIVER FREQUENCY ADJUSTMENTS (Cont'd)

Table 5-11. Standard Values and HP Part Numbers for A3R31 and A3R53

Value	HP Part Number	Value	HP Part Number
1.1K	0757-0424	4.22K	0698-3154
1.21K	0757-0274	4.64K	0698-3155
1.33K	0757-0317	5.11K	0757-0438
1.47K	0757-1094	5.62K	0757-0200
1.62K	0757-0428	6.19K	0757-0290
1.78K	0757-0278	6.81K	0757-0439
1.96K	0698-0083	7.50K	0757-0440
2.15K	0698-0084	8.25K	0757-0441
2.37K	0698-3150	9.09K	0757-0288
2.61K	0698-0085	10.0K	0757-0442
2.87K	0698-3151	11.0K	0757-0443
3.16K	0757-0279	12.1K	0757-0444
3.48K	0698-3152	13.3K	0757-0289
3.83K	0698-3153	14.7K	0698-3156

ADJUSTMENTS

5-17. FREQUENCY REFERENCE ADJUSTMENTS

REFERENCE:

A3 YIG Driver Assembly Schematic (See Figure 5-15 for test point and adjustment locations.)

DESCRIPTION:

The Frequency Reference output accuracy is adjusted across the band by adjusting FRL and FRH controls to corresponding frequencies at the low and high end of frequency band.

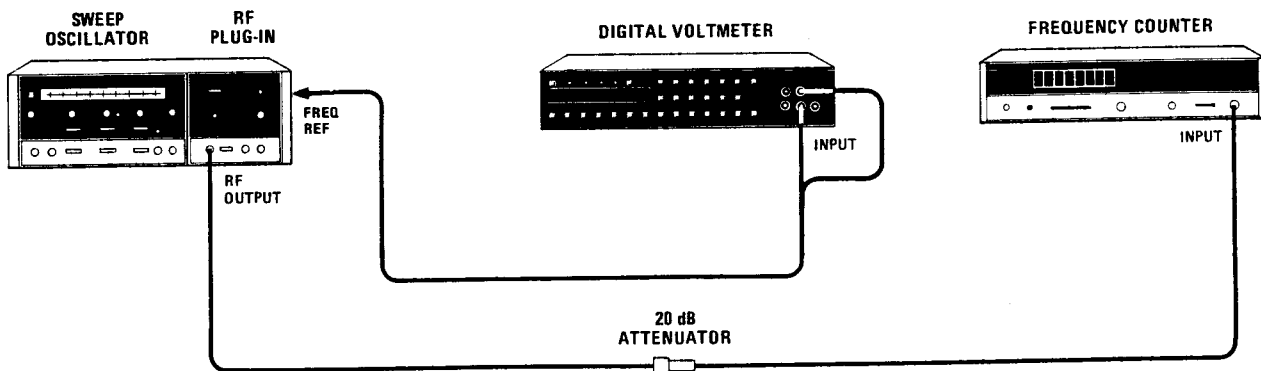

Figure 5-3. Frequency Reference Adjustments Test Setup

EQUIPMENT:

Sweep Oscillator	HP 8620C
Frequency Counter	HP 5340A
Digital Voltmeter	HP 3455A
20 dB Attenuator	HP 8491A, Option 020

PROCEDURE:

1. Connect equipment as shown in Figure 5-3.
2. Set controls as in step 2, paragraph 5-16.
3. Press 8620C LINE Pushbutton ON. Allow 30 minutes warm-up time.
4. Press 8620C CW pushbutton.
5. Connect DVM to FREQ REF output (rear panel).

ADJUSTMENTS

5-17. FREQUENCY REFERENCE ADJUSTMENTS (Cont'd)

- 6. Adjust CW MARKER and CW VERNIER controls for a low end frequency counter indication shown in Table 5-3 ± 0.01 GHz.
- 7. Adjust A3R1 (FRL) for a DVM indication shown in Table 5-12 for low end of band ± 0.01 volt.
- 8. Adjust CW MARKER and CW VERNIER controls for a high end frequency counter indication shown in Table 5-3 ± 0.01 GHz.
- 9. Adjust A3R2 (FRH) for a DVM indication shown in Table 5-12 for high end of band ± 0.01 volt.

Table 5-12. Frequency Reference Voltage Levels

RF Plug-in	Low end of Band	High end of Band
86235A	1.7V	4.3V
86240A	2.0V	8.4V
86240B	2.0V	8.4V
86240C	3.6V	8.6V

5-18. HARMONIC ADJUSTMENTS

REFERENCE:

- A6 Pulse Amplifier/Bias Assembly Schematic
- A3 YIG Driver Assembly Schematic

(See Figure 5-15 for test point and adjustment locations.)

DESCRIPTION:

Harmonics generated by the RF Plug-in are observed and adjusted to a minimum in three steps by use of bandpass filters and a Swept Amplitude Analyzer. Harmonics from 4 to 6 GHz are minimized, then harmonics from 6 to 8 GHz, and finally harmonics from 8 to 12 GHz are minimized.

NOTE

This procedure should only be done if the YIG Oscillator, Amplifier or YIG Driver Assemblies are replaced or repaired, or the harmonics measured in Paragraph 4-12 do not meet specification.

ADJUSTMENTS

5-18. HARMONIC ADJUSTMENTS (Cont'd)

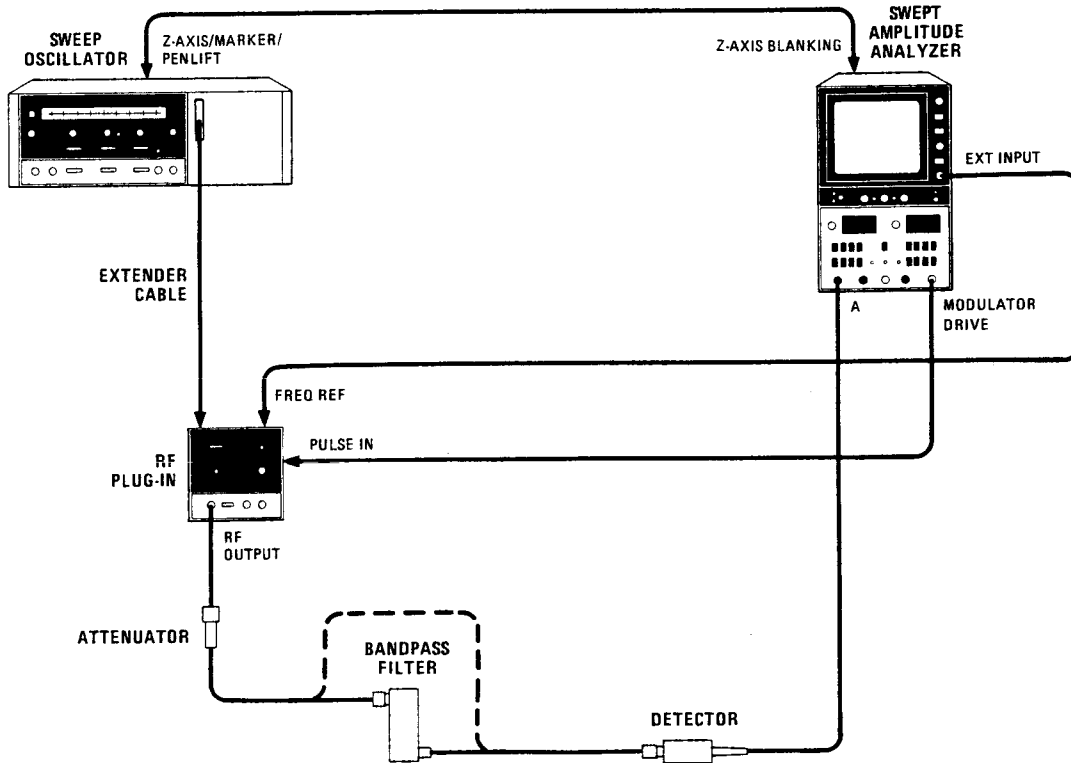

Figure 5-4. Harmonic Adjustments Test Setup

EQUIPMENT:

Sweep Oscillator.....	HP 8620C
Swept Amplitude Analyzer.....	HP 182T/8755B
Attenuator	
(20 dB for 86235A/86240A/C.....)	HP 8491A, Option 020
(6 dB for 86240B).....	HP 8491A, Option 006
4 — 8 GHz Bandpass Filter.....	HP 8435A
6 — 8 GHz Bandpass Filter.....	HP 8433A
8 — 12 GHz Bandpass Filter.....	HP 8436A
Detector.....	HP 11664A
Extender Cable.....	HP 08620-60032

PROCEDURE:

1. Connect equipment as shown in Figure 5-4 omitting the bandpass filter. (Use 20 dB attenuator for 86235A/86240A/C; use 6 dB attenuator for 86240B.)

ADJUSTMENTS

5-18. HARMONIC ADJUSTMENTS (Cont'd)

2. Set controls as follows:

8620C:

MODE AUTO
 TRIGGER..... INT
 TIME-SECONDS 1 — .1
 TIME-SECONDS Vernier Fully clockwise
 MARKERS..... OFF
 RF BLANKING/OFF (rear panel) RF BLANKING
 DISPLAY BLANKING/OFF (rear panel) DISPLAY BLANKING
 1 kHz SQ WV/OFF OFF

RF Plug-in:

RF OFF-ON ON
 POWER LEVEL Fully clockwise
 ALC SWITCH INT or EXT
 SLOPE (Internal Leveling Only) CAL (Fully counterclockwise)

3. Push 8620C LINE pushbutton ON; allow 30 minutes warm-up time. (86240A, 86240C, 86235A, proceed to step 5.)

4. Tracking Adjustments (86240B only)

a. While observing the swept amplitude analyzer display make the following adjustments:

1. Adjust A3R9 (TOS) for best power at low frequency end of band.
2. Adjust A3R10 (TS1) for best power at mid band.
3. Adjust A3R1 (TB) for best power upper mid band.
4. Adjust A3R12 (TS2) for best power at high end of band.
5. Repeat steps 4a3 and 4a4 as necessary.

b. Repeat step 4a until optimum power has been achieved across the entire band.

5. Harmonic Adjustments(External leveling required if Option 001 not installed)

a. Connect the 4 — 8 GHz bandpass filter between the attenuator and the detector.

b. Set RF Plug-in POWER LEVEL control to +13 dbm.

c. Preset the following adjustments as noted:

- A4A1R4: Mid Range (86240A/B/C only)
- A6R17 (DRAIN): Mid range
- A6R10(1): fully counterclockwise
- A6R11(2): fully counterclockwise
- A6R12(3): fully counterclockwise

ADJUSTMENTS

5-18. HARMONIC ADJUSTMENTS (Cont'd)

- d. Set the 8755B VERNIER control to place top of trace one division below top graticule line. (See Figure 5-5.)

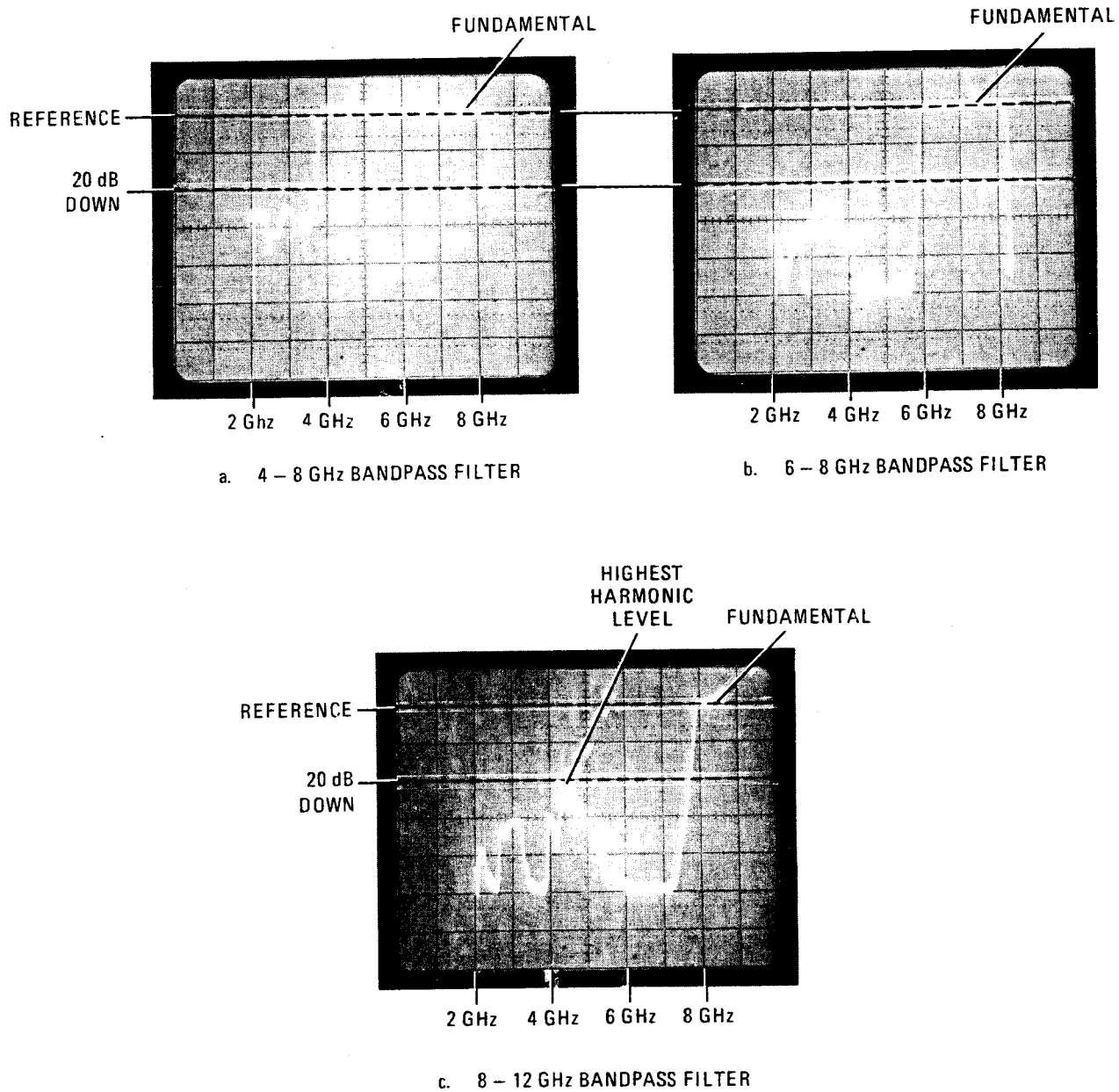

Figure 5-5. 86240A/C, 86235A Harmonics

ADJUSTMENTS

5-18. HARMONIC ADJUSTMENTS (Cont'd)**NOTE**

If RF Plug-in is HP Model 86240C, proceed to step 5g.

- e. Check that the 4 — 8 GHz band pass filter is installed.
- f. Adjust A6R10, R11, R12, R17 for minimum harmonics. (See Figures 5-5 and 5-6.)

NOTE

Because the FREQ REF is used to sweep the 8755B, the horizontal axis will be approximately 1 GHz/div (FREQ REF out = 1V/GHz). The 86235A and the 86240C display will therefore only be a portion of the display shown in Figure 5-5.

- g. Remove 4 — 8 GHz bandpass filter and install 6 — 8 GHz bandpass filter. Repeat step 5f.
- h. Remove 6 — 8 GHz bandpass filter and install 8 — 12 GHz bandpass filter. Repeat step 5f.

NOTE

If RF Plug-in is HP Model 86240A/B/C, adjust A4A1R4 in steps 5f and 5g after completing steps 5e through 5h at least once.

- i. Repeat steps 5e through 5h until no further adjustments are necessary to bring harmonic levels 45 dB below fundamental for the 86240B or 20 dB below the fundamental for the 86240A/C, 86235A.

**NOTE
(86240B Only)**

Readjustment of the tracking adjustments TOS, TS1, TB and TS2 (step 4) may be necessary to bring the harmonic levels within specification. Repeat steps 5d through 5i if tracking is readjusted.

- 6. 86240A, 86240C, 86235A only. Set POWER LEVEL control to +16 dBm. Verify that harmonics are greater than 16 dB below the fundamental using each bandpass filter. If the levels do not meet specification, set POWER LEVEL control to +13 dBm and repeat steps 5d through 5i.

ADJUSTMENTS

5-18. HARMONIC ADJUSTMENTS (Cont'd)

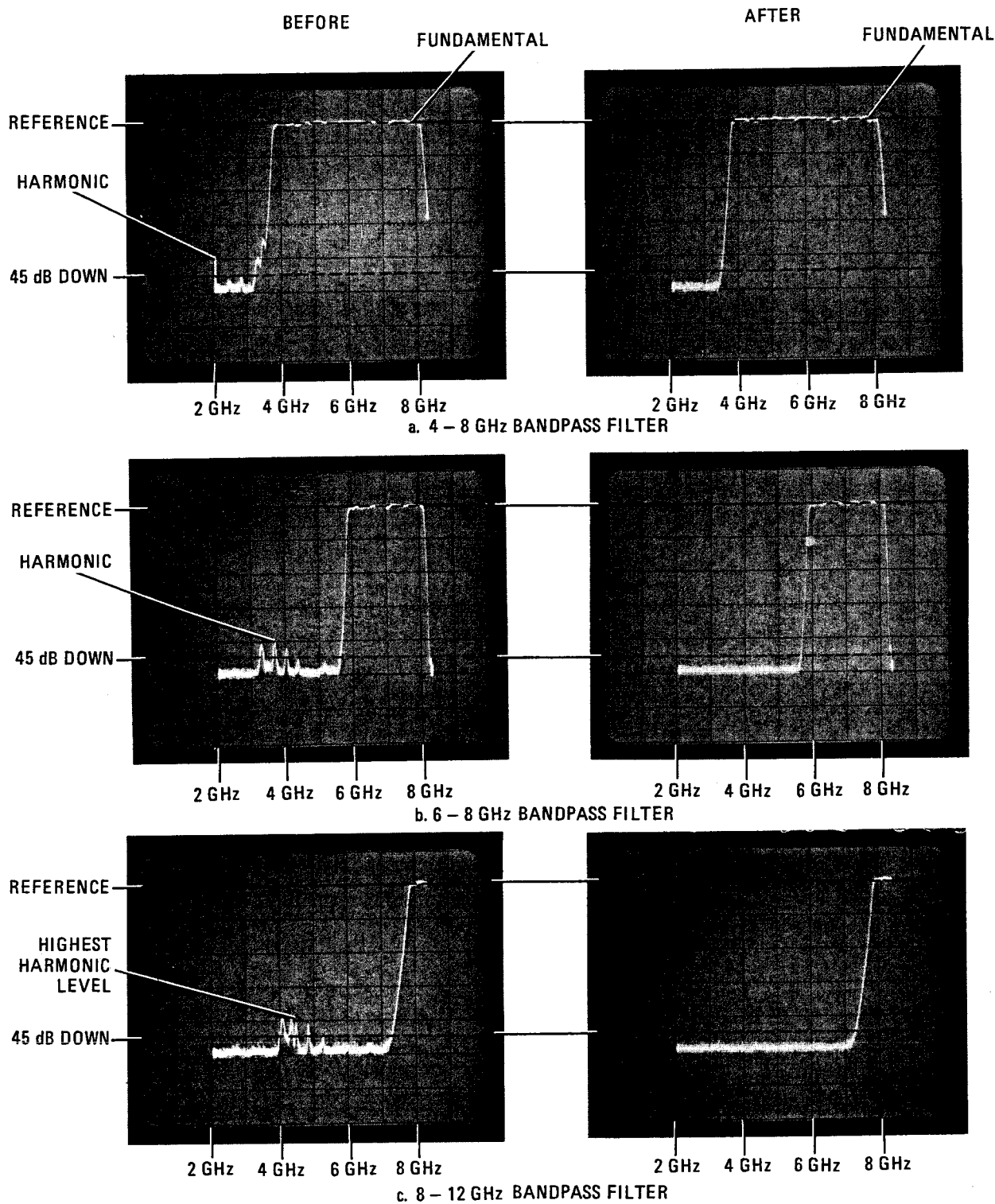

Figure 5-6. 86240B Harmonics Before and After Adjustment

ADJUSTMENTS

5-19. ALC ADJUSTMENTS

REFERENCE:

A2 ALC Assembly Schematic (see Figure 5-15 for test point and adjustment locations.)

DESCRIPTION:

Offset, POWER LEVEL control (Option 001 and 86240B only), Sample and Hold, and flatness are adjusted for Automatic Leveling Control (ALC) circuitry.

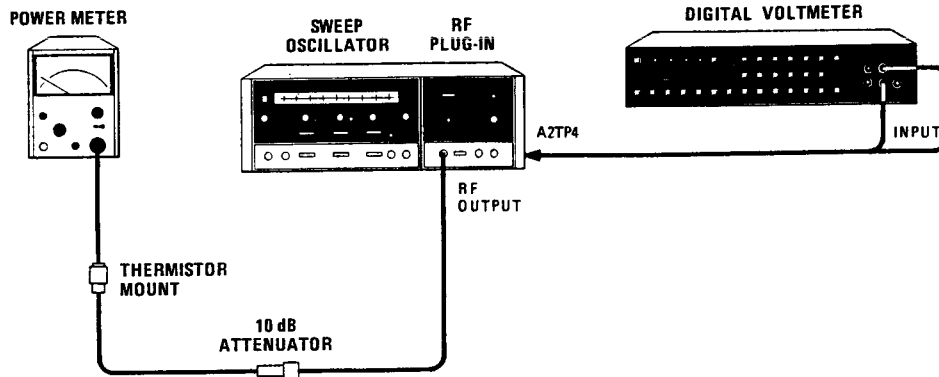

Figure 5-7. OFFSET and Power Control Adjustments Test Setup

NOTE

Equipment listed is for four (4) test setups (Figures 5-7, 5-8, 5-9, and 5-10).

EQUIPMENT:

Sweep Oscillator	HP 8620C
Oscilloscope	HP 180C/1801A/1820C
Swept Amplitude Analyzer	HP 182T/8755B
Power Meter	HP 432A
Thermistor Mount	HP 8478A
Crystal Detector (2 required)	HP 423B
10 dB Attenuator	HP 8491A, Option 010
Digital Voltmeter	HP 3455A
Detector	HP 11664A
50Ω Termination	HP 11593A
Power Splitter	HP 11667A

 ADJUSTMENTS

5-19. ALC ADJUSTMENTS (Cont'd)

PROCEDURE:

1. Connect equipment as shown in Figure 5-7.
2. Set controls as follows:

8620C:

CW MARKER pointer	Center-scale
MODE	AUTO
TRIGGER	INT
TIME-SECONDS	.1 — .01
TIME-SECONDS Vernier	Fully clockwise
RF BLANKING/OFF (rear panel)	RF BLANKING
DISPLAY BLANKING/OFF (rear panel)	OFF
1 kHz SQ WV/OFF (rear panel)	OFF

RF PLUG-IN:

RF OFF-ON	ON
ALC Switch	INT or OFF
ALC GAIN	Fully clockwise
POWER LEVEL	Fully clockwise

3. OFFSET Adjustment
 - a. Press CW pushbutton and adjust CW MARKER pointer to center-scale. Connect A2TP5 to ground.
 - b. Connect DVM to 2TP4 (ground lead to chassis).
 - c. Adjust A2R18 (OS) for a DVM indication of $0.00 \text{ Vdc} \pm 0.002 \text{ Vdc}$.
 - d. Remove ground from A2TP5.
4. If adjustments are being performed on an 86235A, 86240A, or 86240C without internal leveling, proceed to step 8.
5. Power Control Calibration (Option 001 or 86240B Only)

NOTE

If RF POWER LEVEL control or control knob has been replaced or loosened, refer to Section VIII for proper mechanical alignment of R3 and POWER LEVEL control knob.

- a. Press 8620C CW pushbutton. Adjust A2R58 (LD) to mid-range.
 - b. Set front-panel POWER LEVEL control to +16 dBm (+13 dBm 86240B).
 - c. Adjust A2R10 (HI) for a power meter indication of +6 dBm (+3 dBm 86240B) $\pm 0.5 \text{ dB}$.
 - d. Set front-panel POWER LEVEL control to +6 dBm (+3 dBm 86240B).
-

ADJUSTMENTS

5-19. ALC ADJUSTMENTS (Cont'd)

- e. Adjust A2R15 (LO) for a power meter indication of -4 dBm (-7 dBm 86240B) ± 0.5 dB.
- f. Set front-panel POWER LEVEL control to $+11$ dBm ($+8$ dBm 86240B).
- g. Adjust A2R58 (LD) for a power meter indication of $+1$ dBm (-2 dBm 86240B) ± 0.5 dB.
- h. Repeat steps 5a through 5g until no further adjustment is necessary.

6. Sample and Hold Adjustment (Option 001 or 82640B only)

Figure 5-8. Sample and Hold Adjustment Test Setup (Internal Leveling)

- a. Connect equipment as shown in Figure 5-8.
- b. Set POWER LEVEL control to $+6$ dBm ($+3$ dBm, 86240B).
- c. Adjust A2R32 (GAIN) for best square wave response.

7. ALC Flatness Adjustment (Option 001 or 86240B Only)

- a. Connect equipment as shown in Figure 5-9. Set RF Plug-in SLOPE control to CAL (fully counterclockwise). Push 8620C FULL SWEEP pushbutton.
- b. Set POWER LEVEL control to $+16$ dBm ($+13$ dBm, 86240B).
- c. Adjust A2R5 (SLP) for best flatness across band.

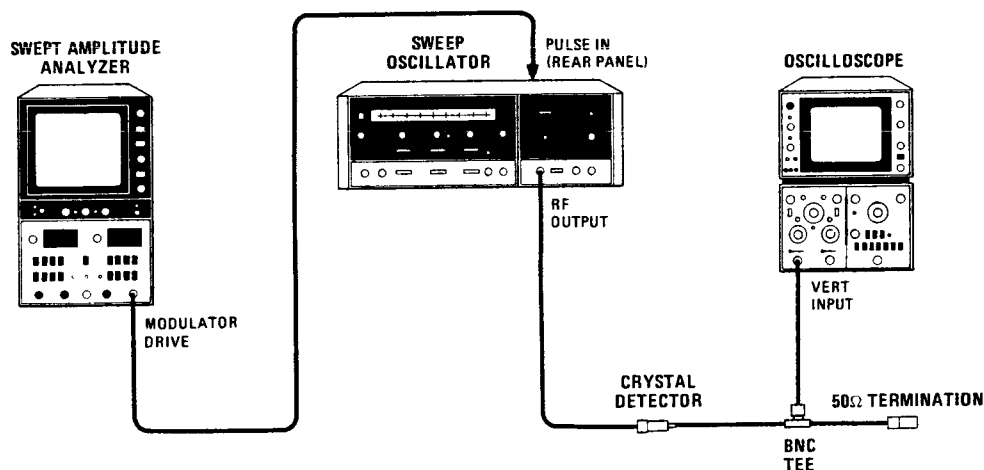
ADJUSTMENTS

5-19. ALC ADJUSTMENTS (Cont'd)

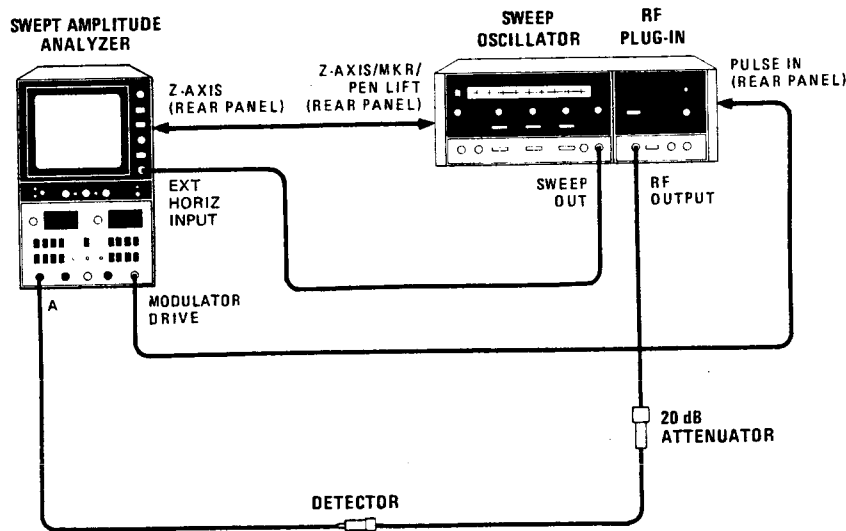

Figure 5-9. ALC Flatness Adjustment Test Setup

8. External Leveling Adjustment (86235A, 86240A, or 86240C without internal leveling installed)

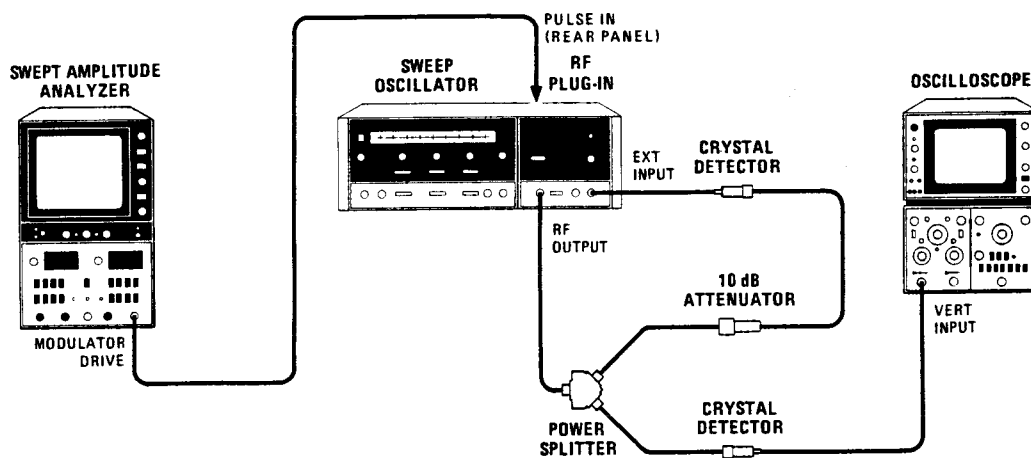

Figure 5-10. Sample and Hold Adjustment Test Setup (External Leveling Only)

- a. Connect equipment as shown in Figure 5-10 without connecting MODULATOR DRIVE.

ADJUSTMENTS

5-19. ALC ADJUSTMENTS (Cont'd)

b. Set controls as follows:

8620C:

MODE AUTO
 TRIGGER..... INT
 TIME-SECONDS1 — .01
 TIME-SECONDS Vernier Fully clockwise

RF PLUG-IN:

RF OFF-ON ON
 ALC switch..... EXT
 ALC GAIN Fully clockwise
 POWER LEVEL Fully clockwise

- c. Press 8620C LINE Pushbutton ON (FULL SWEEP selected). Allow 30 minutes warm-up time.
- d. Rotate POWER LEVEL control counterclockwise until oscillations appear. Adjust ALC GAIN counterclockwise until oscillations disappear. Repeat this process until POWER LEVEL is in fully counterclockwise position.
- e. Connect 8755B MODULATOR DRIVE output to the RF Plug-in PULSE IN connector (rear panel).

5-20. FM DRIVER ADJUSTMENT

REFERENCE:

A1 FM Driver Assembly Schematic (See Figures 5-14 and 5-15 for test point and adjustment locations.)

DESCRIPTION:

FM Offset and Sensitivity are adjusted for optimum frequency modulation performance.

ADJUSTMENTS

5-20. FM DRIVER ADJUSTMENT (Cont'd)

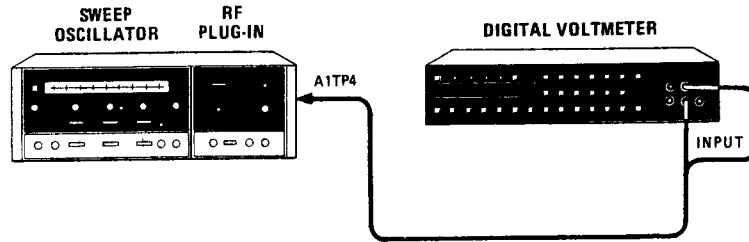

Figure 5-11. FM Offset Adjustment Test Setup

NOTE

Equipment listed is for two (2) test setups (Figures 5-11 and 5-12).

EQUIPMENT:

Sweep Oscillator	HP 8620C
Oscilloscope	HP 180C/1801A/1820C
Frequency Counter	HP 5340A
Digital Voltmeter	HP 3455A
Spectrum Analyzer	HP 8565A
Power Supply	HP 6214A
20 dB Attenuator	HP 8491A, Option 020

PROCEDURE:

1. Connect equipment as shown in Figure 5-11.
2. Set controls as follows:

8620C:

CW MARKER pointer	Center-scale
CW VERNIER pointer	Center-scale
CW VERNIER multiplier	X.1
MODE	AUTO
TRIGGER	INT
TIME-SECONDS	.1 — .01
TIME-SECONDS Vernier	Fully clockwise
1 kHz SQ WV/OFF (rear panel)	OFF
DISPLAY BLANKING/OFF (rear panel)	OFF

RF PLUG-IN:

RF OFF-ON	ON
ALC switch	OFF or INT
POWER LEVEL	Fully clockwise
FM-NORM-PL (MLA-NORM) switch	FM (MLA)

ADJUSTMENTS

5-20. FM DRIVER ADJUSTMENT (Cont'd)

3. FM Offset Adjustment (86240A, 86240B, 86235A without Option 008 Only)
 - a. Adjust A1R3 for $-9.0V \pm 0.1V$ indication on DVM as measured at A1TP4.
4. FM Sensitivity Adjustment

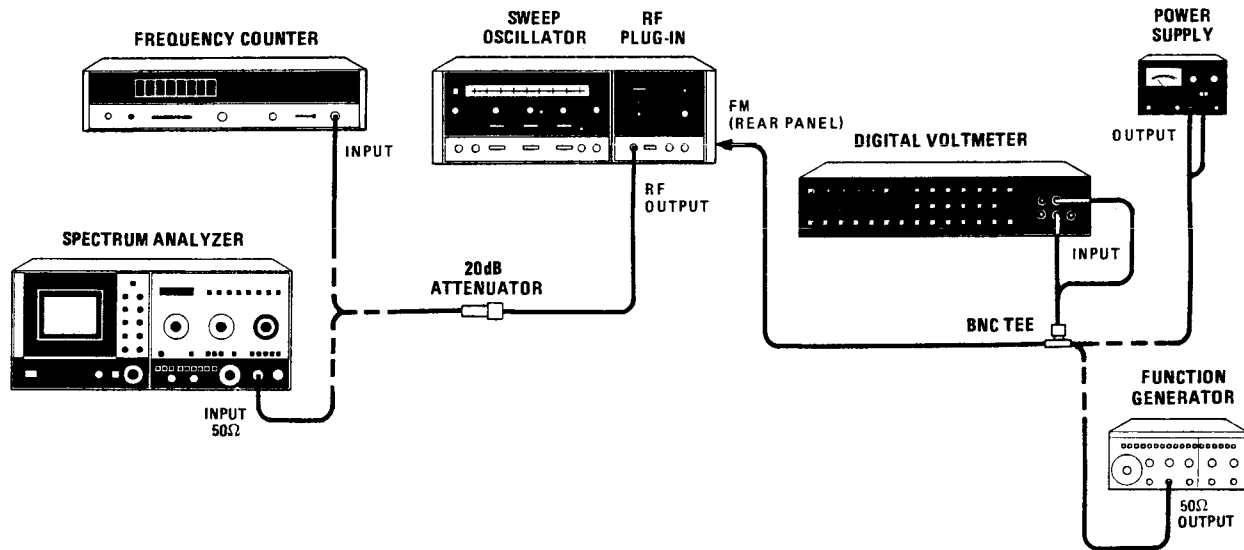

Figure 5-12. FM Sensitivity Adjustment Test Setup

- a. Connect equipment as shown in Figure 5-12. Do not connect power supply to rear-panel FM input. Connect frequency counter to RF OUTPUT.
- b. For 86240C and 86235A Option 008 proceed to step 4l.
- c. Adjust power supply for $-1.0 Vdc \pm 0.01 Vdc$ indication on DVM.
- d. Adjust CW MARKER and CW VERNIER controls for frequency counter indication of 5.000 GHz for 86240A/B or 3.000 GHz for 86235A.
- e. Connect power supply output to FM input.
- f. Adjust A1R1 (LFG) for frequency counter indication of 5.020 ± 0.01 GHz for 86240A/B or 3.020 ± 0.001 GHz for 86235A.
- g. Disconnect power supply from FM input. Note frequency counter indication. If necessary repeat steps 4b through 4f.
- h. Set RF Plug-in rear-panel FM-NORM-PL switch to NORM. Note frequency counter indication; frequency should be 5.000 GHz for 86240A/B or 3.000 GHz for 86235A as noted in step 4d.

 ADJUSTMENTS

5-20. FM DRIVER ADJUSTMENT (Cont'd)

- i. Connect Spectrum Analyzer to RF OUTPUT and center signal on CRT display.
- j. Set Function Generator for 1 kHz 0.2V p-p sine wave output and connect to FM input.
- k. Adjust A1R2 (HFG) for a peak to peak deviation on spectrum analyzer display of 4 MHz ± 0.1 MHz.

NOTE

Perform FM Frequency Response Test, Paragraph 4-19 (steps a through n) in Section IV. If RF Plug-in does not meet frequency response specification, compromise A1R2 (HFG) adjustment.

86240C or 86235A Option 008 only

- l. Adjust power supply for +1.0 Vdc ± 0.01 Vdc indication on DVM.
- m. Adjust CW MARKER and CW VERNIER controls for frequency indication of 5.000 GHz for 86240C or 3.000 GHz for 86235A Option 008.
- n. Connect power supply output to FM input.
- o. Adjust A1R11 (LFG) for frequency counter indication of 5.020 ± 0.001 GHz for 86240C or 3.020 ± 0.001 GHz for 86235A Option 008.
- p. Disconnect power supply from FM input. Note frequency counter indication. If necessary, repeat steps 4l through 4o.
- q. Set RF Plug-in rear-panel MLA-NORM switch to NORM. Note frequency counter indication frequency should be same as in step 4a.
- r. Adjust power supply for +0.5 Vdc ± 0.01 Vdc indication on DVM. Reconnect power supply to FM input.
- s. Adjust A1R2 (HFG) for frequency counter indication of 5.010 ± 0.001 GHz for 86240C or 3.010 ± 0.001 GHz for 86235A Option 008.

5-21. FM FREQUENCY RESPONSE ADJUSTMENT (86240C, 86235A OPTION 008 ONLY)
REFERENCE:

A1 FM Driver Assembly Schematic (See Figures 5-14 and 5-15 for test point and adjustment locations.)

DESCRIPTION:

FM Deviation of the RF Plug-in is compared to a known voltage reference using a delay line discriminator. The two signals being compared are displayed on an oscilloscope and frequency response of RF Plug-in is adjusted.

ADJUSTMENTS

5-21. FM FREQUENCY RESPONSE ADJUSTMENT (86240C, 86235A OPTION 008 ONLY) (Cont'd)

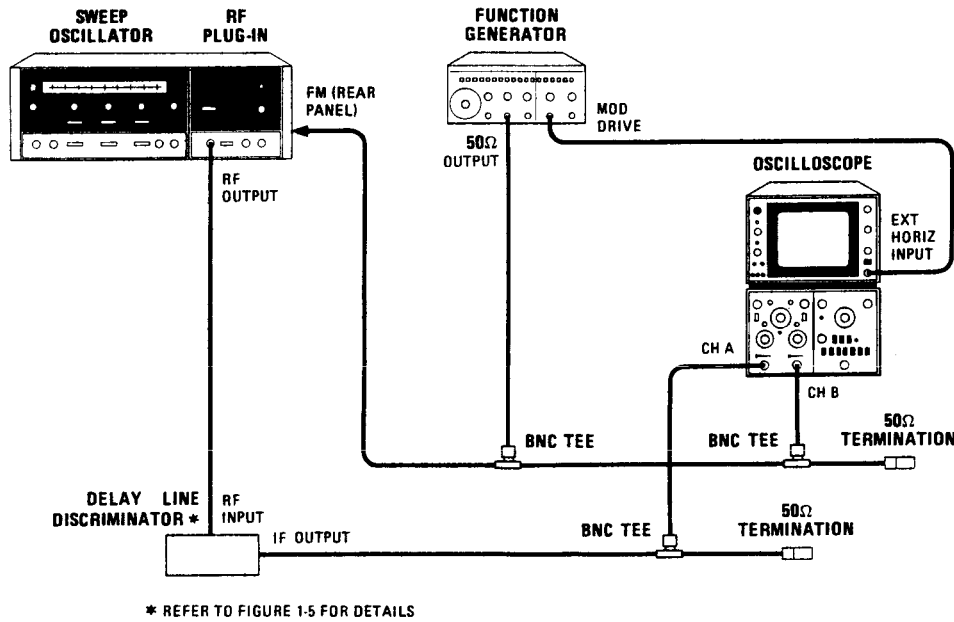

Figure 5-13. ALC Flatness Adjustment Test Setup

EQUIPMENT:

Sweep Oscillator.....	HP 8620C
Oscilloscope.....	HP 180C/1801A/1820C
Function Generator.....	HP 3312A
BNC Tee (3 required).....	HP 1250-0781
50-Ohm Termination (2 required).....	HP 11593A
Extender Board.....	HP 5060-0049
Delay Line Discriminator.....	(See Figure 1-5)

PROCEDURE:

1. Connect equipment as shown in Figure 5-13 and place A1 FM Assembly on extender board.
2. Set controls as follows:

8620C:

CW MARKER pointer.....	Center-scale
RF BLANKING/OFF (rear panel).....	OFF
1 kHz SQ WV/OFF (rear panel).....	OFF
DISPLAY BLANKING/OFF (rear panel).....	OFF

ADJUSTMENTS

5-21. FM FREQUENCY RESPONSE ADJUSTMENT (86240C, 86235A OPTION 008 ONLY) (Cont'd)

RF PLUG-IN:

RF OFF-ON	ON
ALC switch	OFF or INT
POWER LEVEL	Mid-range
MLA-NORM (rear panel)	MLA

FUNCTION GENERATOR:

MODULATION	SWP
MODULATION RANGE	100
MODULATION RANGE Vernier	Fully clockwise
Amplitude1 — 1
SYM.	CAL
Modulation Start Frequency	30° from full clockwise
Frequency Dial (SWP STOP)	10
Function	~
Range	1 kHz

OSCILLOSCOPE

Horizontal Display	EXT
Vertical Display	CH B
Volts/DIV	
CH A	0.005
CH B	0.02
INPUT	DC

3. Frequency Response Adjustments

- a. Press 8620C LINE pushbutton, press CW and CW VERNIER pushbuttons.
- b. Adjust GROUND REF of CH A and CH B of oscilloscope to center graticule line; select CH B.
- c. Adjust function generator amplitude vernier control for 8 divisions peak-to-peak display as indicated on oscilloscope.
- d. Select oscilloscope CH A and adjust CW VERNIER and POWER LEVEL controls for signal display of 4 divisions peak-to-peak centered about 0V.
- e. Select CH B. Adjust oscilloscope VOLTS/DIV CAL knob for 4 divisions of display.
- f. Set oscilloscope display to CHOP B mode. CH A and CH B signal traces should coincide. If not, adjust CW VERNIER control to align both signal traces.
- g. Adjust function generator frequency range slowly between 1 kHz and 1 MHz and note variation of CH A display with respect to CH B display.

ADJUSTMENTS

5-21. FM FREQUENCY RESPONSE ADJUSTMENTS (86240C, 86235A OPTION 008 ONLY) (Cont'd)

- h. Using oscilloscope vertical position controls, align both signal traces at bottom edge.
- i. Adjust A1R28 (P1) to align CH A and CH B signal traces as closely as possible over function generator range of 1 kHz to 1 MHz.
- j. Adjust function generator frequency range slowly between 1 MHz and 5 MHz and note variation of CH A display with respect to CH B display.
- k. Adjust A1R27 (P2) to align CH A and CH B signal traces as closely as possible over function generator range of 1 MHz to 5 MHz.
- l. Adjust function generator frequency range slowly between 5 MHz and 10 MHz and note variation of CH A display with respect to CH B display.
- m. Adjust A1R15 (Q) to align CH A and CH B signal traces as closely as possible over function generator range of 5 MHz to 10 MHz.
- n. Repeat steps 3g through 3m as required to achieve best alignment of CH A and CH B traces over full range of 1 kHz to 10 MHz.
- o. Remove extender board and replace A1 FM Assembly.

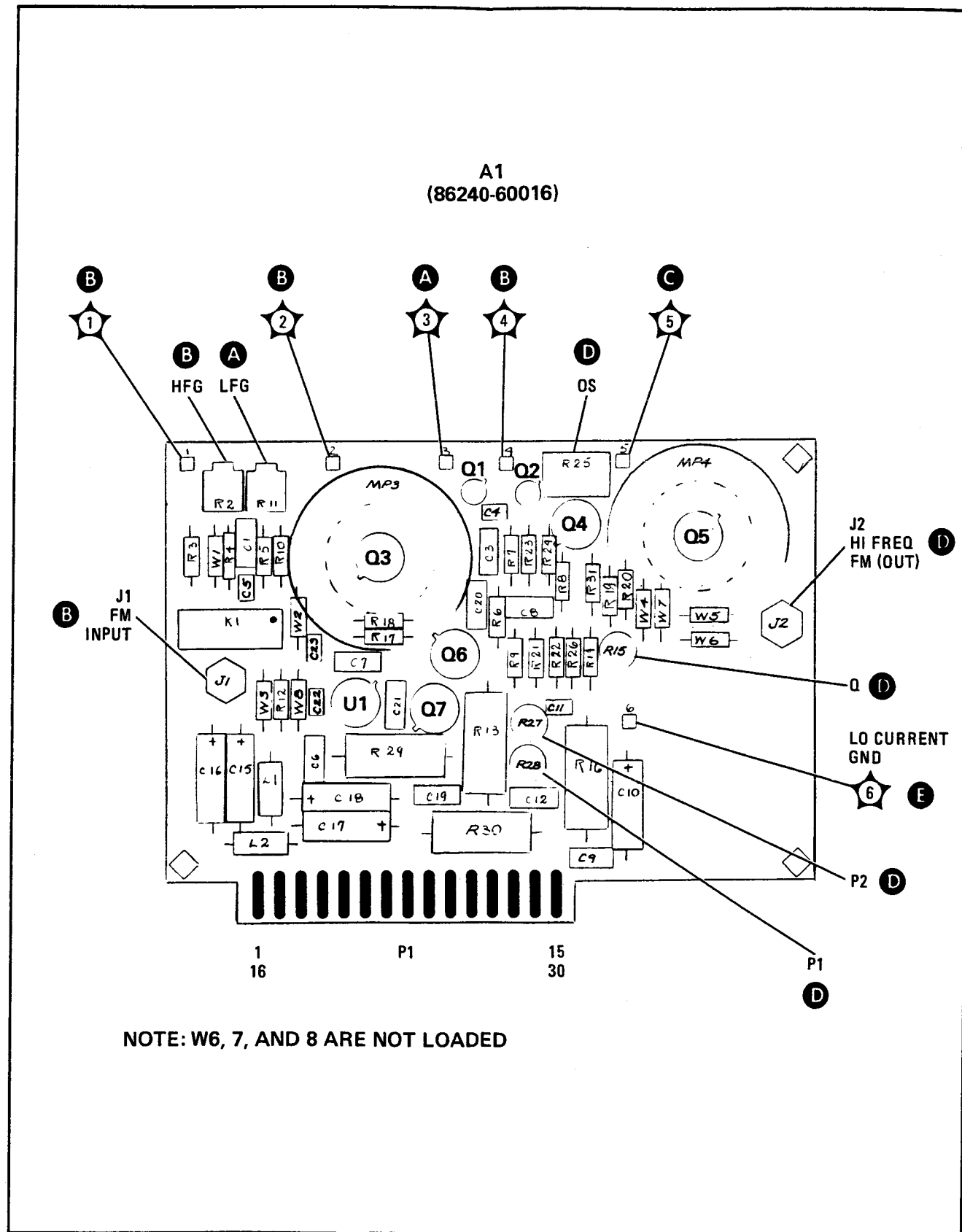

Figure 5-14. Test Point and Adjustment Locations for 86235A Option 008 and 86240C A1 FM Assembly

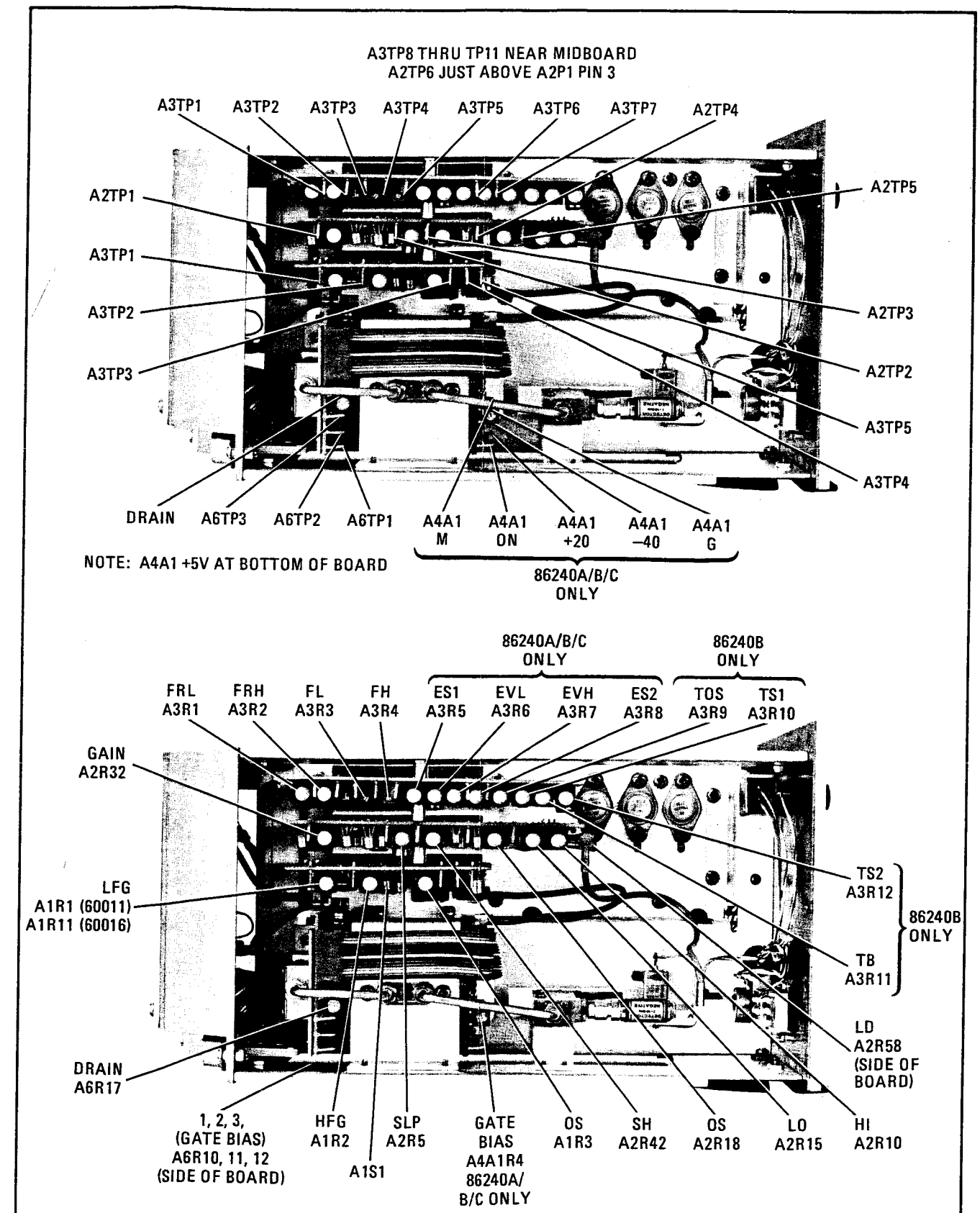

Figure 5-15. Test Point and Adjustment Locations

